

Large excess heat production in Ni-H systems

S. FOCARDI⁽¹⁾, V. GABBANI⁽²⁾, V. MONTALBANO⁽²⁾, F. PIANTELLI⁽²⁾
and S. VERONESI⁽²⁾

⁽¹⁾ *Dipartimento di Fisica, Università di Bologna e INFN Sezione di Bologna - Bologna, Italy*

⁽²⁾ *Dipartimento di Fisica, Università di Siena e Centro IMO - Siena, Italy*

(ricevuto il 9 Marzo 1996; revisionato il 16 Settembre 1996; approvato il 30 Giugno 1998)

Summary. — Evidence of a large heat excess produced in Ni-H systems and details of the calorimetric measurements are reported in this paper. Two cells which ran for long periods (about 300 days) produced an energy excess of 600 MJ and 900 MJ, respectively.

PACS 25.70Ji – Fusion and fusion-fission reactions.

1. – Introduction

In a previous paper [1] some of us reported on the existence of an anomalous heat production observed in hydrogen-loaded nickel rods. The phenomenon occurs when a cell containing a nickel rod is maintained at temperatures above a critical value and is filled with gaseous H₂ at subatmospheric pressures.

A constant input power was used to raise and keep the cell temperature constant at its working value (corresponding to about 700 K for the Ni rod). It was possible to induce an increase of the sample temperature from its working value to about 820 K. This anomalous equilibrium condition will be referred in the following as *excited state*. The system was able to remain in the *excited state* for several months.

The experimental cell described in ref. [1] was successively modified and also a new cell was built with an improvement which allows the measurement and the monitoring of the external surface temperature.

With this new set-up, the external temperature increase, together with the internal one, have been utilized to characterize the *excited state* of the Ni sample. The existence of an exothermic effect, whose heat yield is well above that of any known chemical reaction, has been unambiguously confirmed by evaluating the thermal flux coming from the cells.

An important feature of our systems is that they can remain in the *excited state* for a long time. This characteristic allowed us to search for ionizing radiation coming from the cells. Very clear evidence of neutrons and γ -rays has been reported by us [2-4]. Systematic studies of such processes and their correlation with heat production are in progress.

Evidence of a heat excess have been also obtained by many authors [5] but almost all of the experimental (and theoretical) research in this field is concerned with palladium-deuterium systems in electrolytic devices. In any case, electrolytic systems did not produce energy for long times, according to papers until now in the literature. This could be a possible reason why in these experiments very little evidence of radiation emission was obtained with results normally qualitative and when quantitative [6] very close to the background level.

2. – Experimental apparatus

In the following we shall describe two experimental cells which will be referred to cell A and B. Cell A (fig. 1a) is the same as that we used in the experiment described in ref. [1], B is a new cell. The cell A, containing only one metal rod, is now equipped with a type K chromel-alumel thermocouple having a sensitivity of about $10 \mu\text{V/K}$ in the region of interest. One of the two thermocouple junctions is fixed to the external surface, while the reference one is immersed in a water containing dewar. Water temperature and room temperature are continuously recorded. Voltage measurements are performed with multimeters METEX M4650.

Cell B (see fig. 1b) is constructed in a similar way. The cell vessel is a stainless steel tube ($d_{\text{in}} = 22 \text{ mm}$, $d_{\text{ext}} = 28 \text{ mm}$, length = 150 mm) ending with commercial vacuum fittings flanges CF35. A second stainless steel tube ($d_{\text{in}} = 34 \text{ mm}$) is placed around this vessel to create an interspace and to allow a fast cooling of the cell, if necessary. The heater, supplied by means of a d.c. voltage stabilized power supply (Alpha Electronica mod. AL818), is a Ni-Cr wire fastened around a ceramic cylinder (external diameter 21 mm). A ceramic holder keeps four metal rods symmetrically set around the cell axis where the thermocouple Tc_2 is placed. Due to the high cell working temperature (about 700 K) electrical insulation and gluing inside the cell are done with ceramic bonding.

The cell is equipped with three other thermocouples, Tc_1 , Tc_4 (external) and Tc_3 (internal), placed as shown in fig. 1b, to have a more complete temperature map. All the thermocouples are type K, with an accuracy better than 0.3 K; their reference junctions are immersed in a water containing dewar, at a controlled temperature.

Electrical feedthroughs are done by means of a BTJ8 vacuum fitting (from RIAL - Parma, Italy) and the cell is connected to the gas handling system by means of a commercial DN25 vacuum fitting with aluminium seal. The pressure inside the cell is measured by a piezomanometer (WSE-Waldsee Electronic).

Data acquisition (temperatures, pressure, voltage and current) is performed by means of a PC (CPU 80486) equipped with a 12-bit National Instrument interface card utilizing a Labview software.

We have utilized a rotary pump for primary vacuum and a turbomolecular pump for degassing of cells and samples.

Figure 1c shows the experimental set-up utilized for both the cells.

In order to compare samples having the same surface but different bulks, the metal rods used in the experiments described here (stainless steel for cell A and nickel for cell B) were coated with a thick ($\approx 0.1 \text{ mm}$) nickel layer by the usual nickel-plating bath [7] containing the following components: Nickel Ammonium Sulphate, Citric Acid, Ammonium Hydroxide, Sodium Disulfite (purity RPE-ACS). After introduction in the cells, the rods were annealed under vacuum ($p < 10^{-4} \text{ mbar}$) at temperatures up to about 900 K in order to clean their surfaces [8,9]. Successive thermal cycles were also performed in a hydrogen atmosphere below 1 bar.

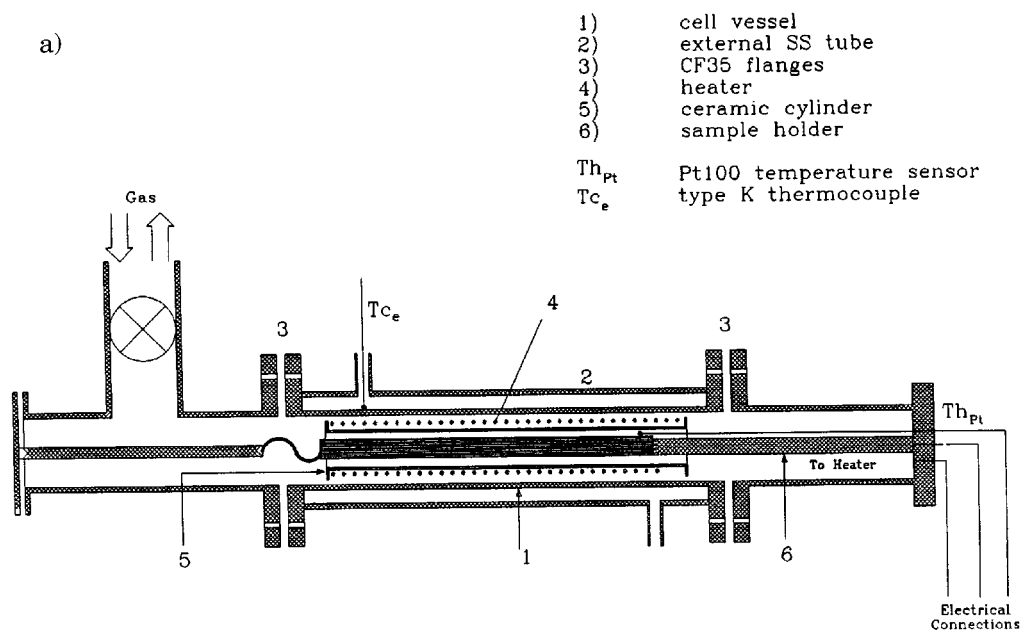

Fig. 1a. – Schematic drawing of cell A. T_{c_e} and $T_{h_{Pt}}$ show the temperature sensor positions.

3. – Calorimetry

Our experimental apparatuses were mainly built to allow the measurement of the heat production triggered in Ni sample after several thermal cycles in H_2 atmosphere. Each calorimetric cell allows a continuous monitoring of its energy balance by measuring the equilibrium temperature at different cell positions (see figs. 1 for temperature sensors position). A constant power is supplied to each cell and the power output is obtained from the calibration procedure described below. The presence of an excess heat source is detected by the increase of all the monitored temperatures.

In particular, the external wall temperature of the cell depends on its heat exchange coefficient and on the thermal power produced or applied inside the cell. Our calorimetric cells can be regarded from this point of view as *black boxes*. At constant external conditions, an equilibrium temperature increase of the wall is related to an extra heat production, if the power input remains unchanged.

Let P_{in} be the electrical power supplied to the cell heater and T_0 the thermal bath temperature (room temperature in our case). At the thermal equilibrium a difference between the temperature of the wall T_w (T_e for cell A and T_4 for cell B) and T_0 is measured. If $\lambda(T)$ is the heat exchange coefficient between the wall and the bath, the following relation must be verified:

$$(1) \quad P_{in} = \lambda(T_w - T_0) = \lambda \Delta T_w.$$

If some kind of physico-chemical process occurs into the cell and H_i are the related en-

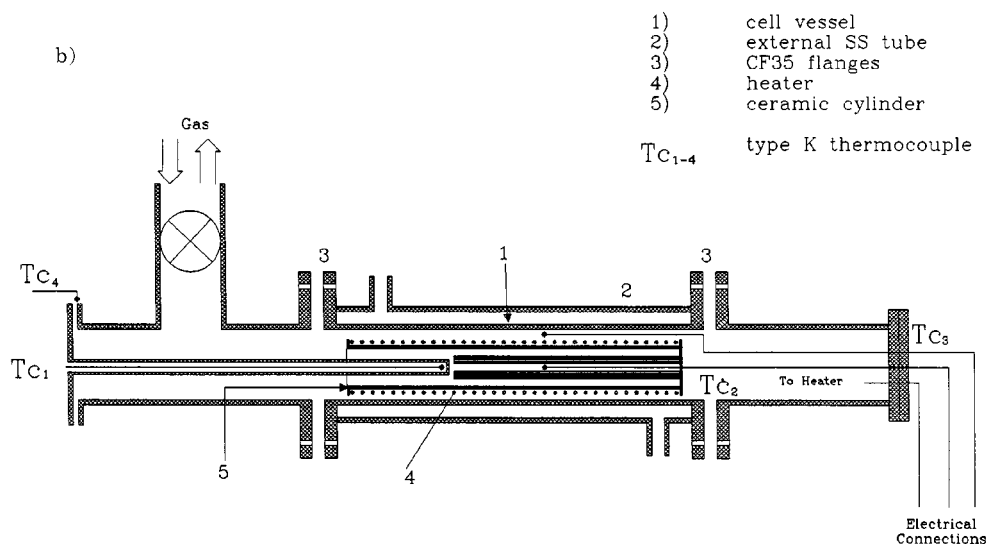

Fig. 1b. – Schematic drawing of cell B. Tc₁, Tc₂, Tc₃ and Tc₄ show the thermocouples positions.

thalpy variations, the following relation holds:

$$(2) \quad P_{\text{in}} + \sum_{i=1}^n \frac{dH_i}{dt} = C \frac{dT_w}{dt} + \lambda(T_w - T_0),$$

where C is the cell heat capacity. Equation (2) is valid if the characteristic times of the heat exchanges inside the cell are shorter than $\tau_c = C/\lambda$ (cell time constant). If all the physico-chemical processes last for a limited time period before stopping, eq. (2) reduces to eq. (1) in few cell time constants. In the case for which one process (the j -th) does not stop and $P_j = \frac{dH_j}{dt} \rightarrow \text{constant}$, on assuming quasi-stationary conditions, that is that the temperatures of the cell remain practically constant during a few cell time constant, one obtains

$$(3) \quad P_{\text{in}} + P_j = \lambda(T_f - T_0) = \lambda \Delta T_f,$$

where T_f is the final wall equilibrium temperature. In our experiments, since the processes are exothermic, $P_j > 0$ and $T_f > T_w$.

From eq. (3) and (1), for the same input power, P_j becomes

$$(4) \quad P_j = \lambda(\Delta T_f - \Delta T_w)$$

if λ can be considered as a constant in the explored temperature range.

Thus, the power generated or absorbed by the j -th process occurring in the cell is proportional to the temperature variation of the cell when the new equilibrium temperature T_f is reached, at a constant input power.

The instrumental constant λ can be obtained from a calibration procedure during which a known power is supplied to the cell and the equilibrium temperatures T_w and T_0 are measured.

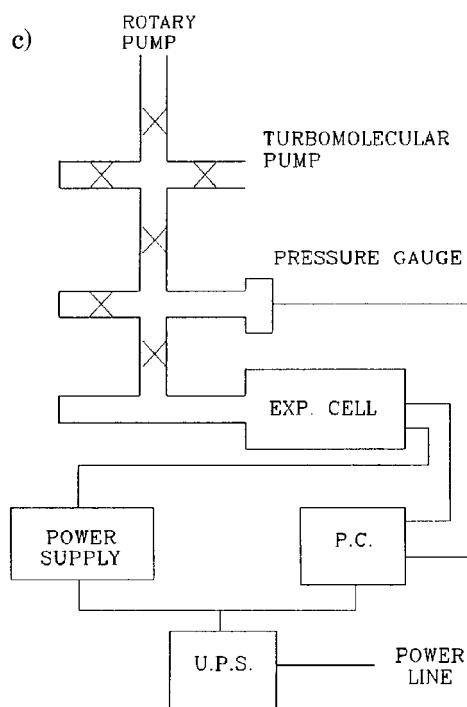

Fig. 1c. – Experimental set-up.

We have measured the temperatures T_w by supplying power up to about 150 W for the cell A and up to 70 W for the cell B in successive steps. Results are shown in fig. 2. From the calibrations, it is possible to evaluate the heat exchange coefficient, $\lambda_A = 1.30 \pm 0.05$ W/K and $\lambda_B = 2.71 \pm 0.06$ W/K for cells A and B, respectively, at a working temperature of the sample ($T \approx 700$ K).

4. – Results and discussion

The sample loading in a natural hydrogen atmosphere was performed in successive steps. In each step, we started with an initial gas pressure in the range 400–800 mbar and thereafter a little amount of hydrogen was introduced into the cell through a suitable valve ($\Delta p \approx 400$ –600 mbar). When the pressure decreased down to its starting value, new hydrogen was added (see fig. 3). After several loading cycles, the sample was ready and it was possible to trigger the exothermic process. Such an operation can be performed by lowering the input power, waiting for the sample temperature to decrease down to about 300 K, then suddenly restoring the previous power level. After this operation an increased equilibrium temperature, as shown in fig. 4, is obtained: the cell is producing an excess heat. Another way to trigger the process is to provoke a pressure step-like variation, as shown in fig. 5. After the triggering procedure, the production of excess heat is maintained for months.

It must be underlined that, once the heat producing process has been started, the cells are kept sealed for all the time, that is no H_2 or anything else is introduced or extracted

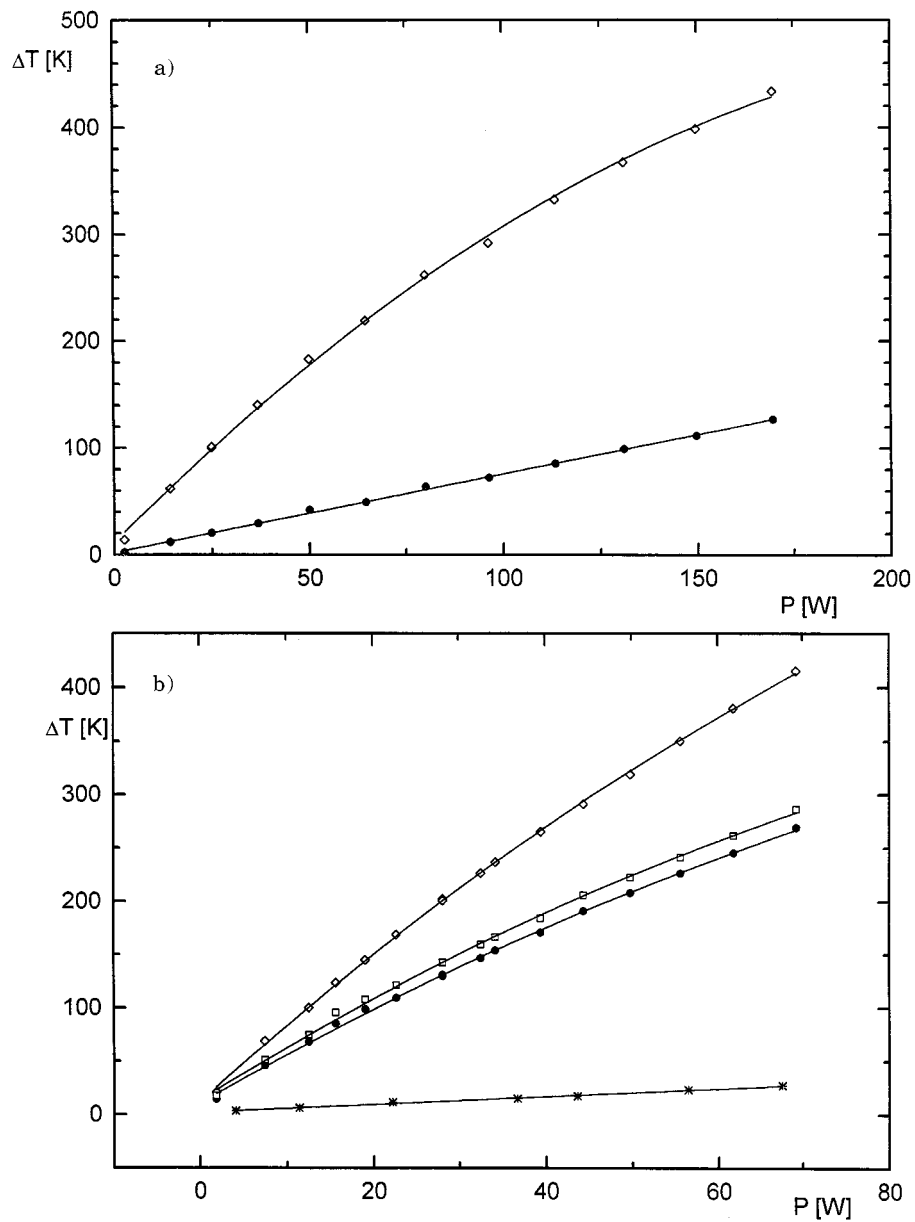

Fig. 2. – a) Cell A. Calibration curves; temperature (relative to the room temperature) vs. power (T_{Pi} (\diamond) and T_e (\bullet)). b) Cell B. Calibration curves; temperature (relative to the room temperature) vs. power (T_1 (\diamond), T_2 (\bullet), T_3 (\square) and T_4 ($*$)).

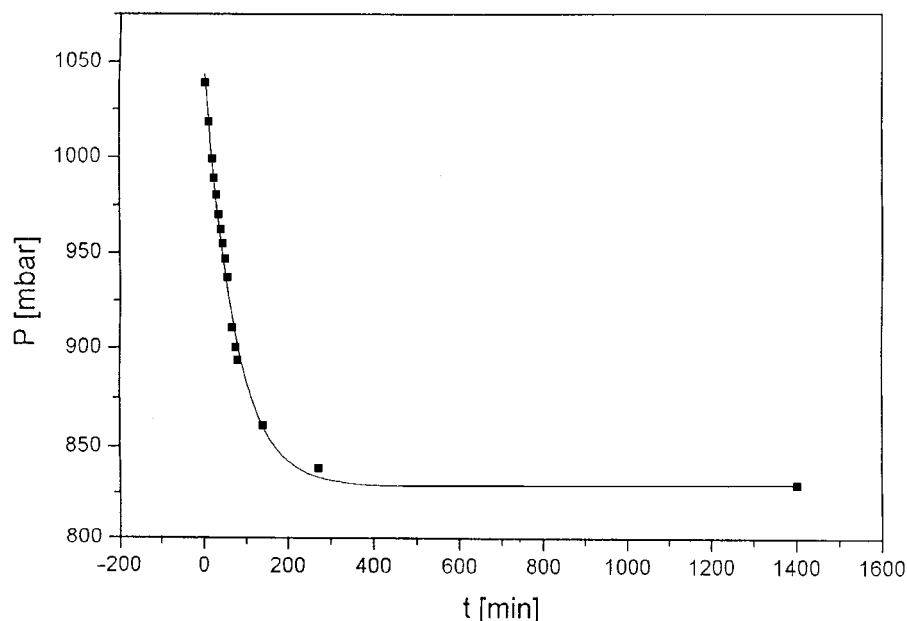

Fig. 3. – A typical hydrogen loading of a sample. The plot refers to cell B. The experimental data can be fitted with an exponential law. The characteristic time for this data set is $\tau = 72$ min.

from the cell, except heat, of course, while the input power is maintained constant. The initial temperatures are newly obtained when the heat producing process is stopped by following a suitable procedure (see fig. 5 and relative caption).

Cell A

Initially on supplying 149.6 W to the cell the equilibrium temperatures were 400.8 K and 113.6 K above T_0 for the sample (T_{Pt}) and the cell (T_e), respectively. After the triggering procedure the temperatures showed a sudden increase (to 411.4 K and 118.0 K for T_{Pt} and T_e , respectively) while the supplied power decreased to 148.9 W (due to the heater resistance increase). Then, the temperatures slowly increased forcing us to lower the input power twice. The equilibrium was reached at 432.5 K and 106.5 K above T_0 for T_{Pt} and T_e , respectively, with a supplied power of 101.5 W.

Summarizing, the input power decrease (48.1 W) would produce in our experimental conditions a decrease of 37 K for T_e , while a decrease of only 7.1 K was observed. In spite of the input power reduction, the sample temperature T_{Pt} increased by 31.7 K.

From the λ_A value and the supplied power difference, it is possible to evaluate a power excess produced by the sample of 38.9 ± 1.5 W.

The power excess from the sample temperature variation, evaluated by the method used in ref. [1], gives a value of 68 W.

Such a discrepancy can be explained by taking into account that the sample calibration curve was obtained before the process was triggered. When the cell is in the *excited state*, the nickel rod becomes a heat emitter. The thermometer outside the cell probes the total heat, regardless of its origin, while the thermometer close to the nickel feels differently

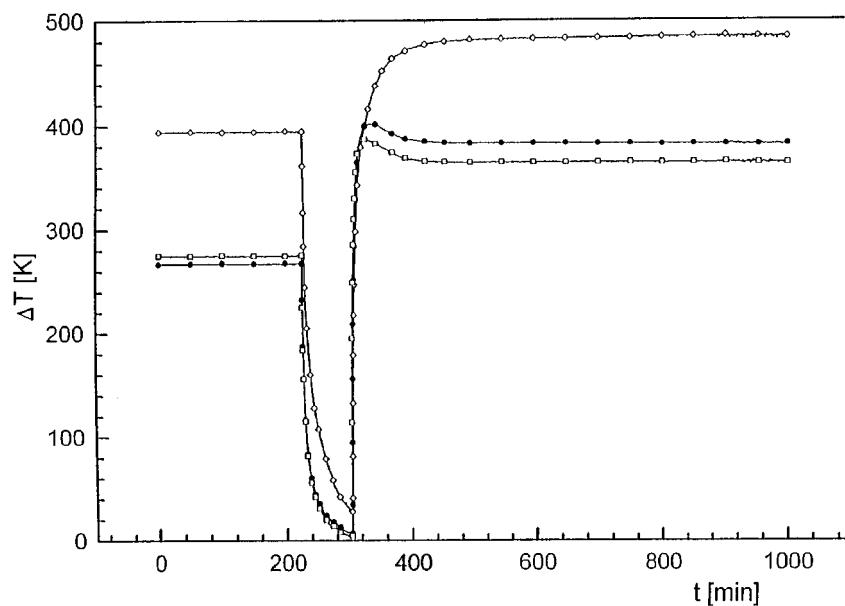

Fig. 4. – A sample excitation performed with a temperature jump for cell B ($T_1(\diamond)$, $T_2(\bullet)$, $T_3(\square)$). An inversion between T_2 and T_3 can be observed. Such an effect is due to the extra power produced by the nickel rod.

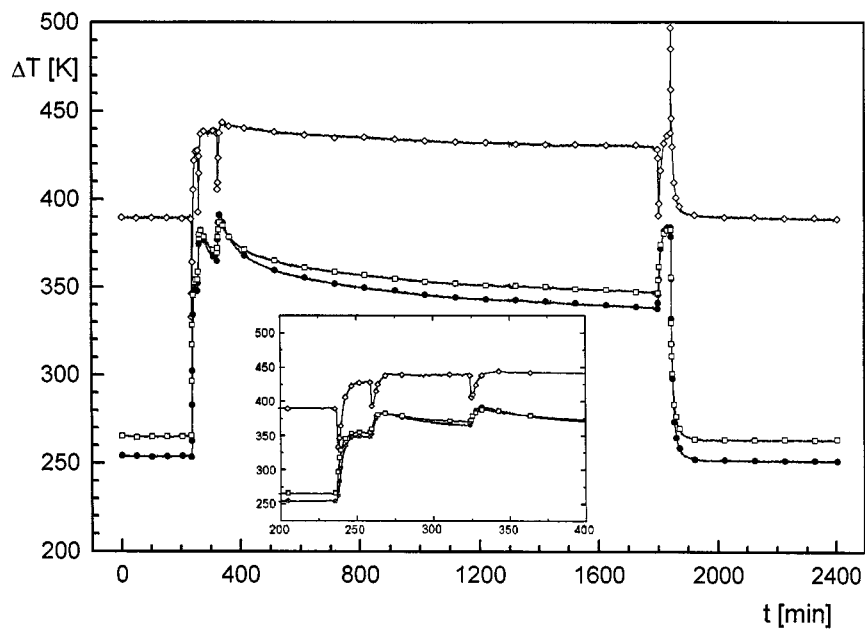

Fig. 5. – A sample excitation (three negative pressure jumps) and a successive deexcitation (vacuum followed by a pressure jump) for cell B ($T_1(\diamond)$, $T_2(\bullet)$, $T_3(\square)$). The detail of the excitation is shown in the square.

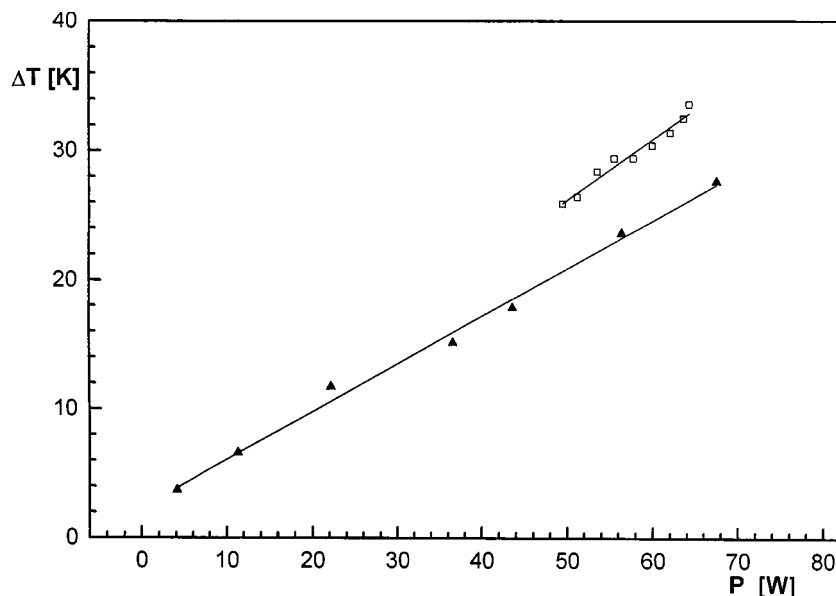

Fig. 6. – T_4 (relative to the room temperature) vs. power for cell B. The upper points(□) refer to the *excited state*; the lower curve is the calibration one.

the heat emitted from the coil and that emitted from the sample. Moreover the sample is thermally connected with the outside along the cell axis (see fig. 1a), and the power measured from the wall temperature does not take into account such contribution. In any case, in the following, we will refer to the lower value of the power, that is that measured externally.

Cell A produced an excess power continuously for 278 days and it increased slowly during this period.

Before the shut-down, this cell was working with an input power of 94.3 W and the sample temperature T_{P_t} of 429.7 K above T_0 . Moreover as a further proof of an extra power in the nickel rod we performed the following measurement: after the shut-down the same working temperature was obtained by supplying 166.3 W.

Cell B

The behaviour of this cell was very similar to that of cell A. In the experimental conditions the input power was 61.8 W and the equilibrium temperatures (above the ambient temperature T_0) 381.7 K, 246.0 K, 262.3 K, 22.9 K for T_1 , T_2 , T_3 and T_4 , respectively. After the triggering process these temperatures increased up to 467.4 K, 367.0 K, 325.6 K and 31.4 K, respectively, at a constant input power.

From the calibration data it is possible to evaluate an excess power, in the cell, of 23.0 ± 1.3 W (from T_4). By utilizing the T_1 calibration curves it is possible to give a rough evaluation of ≈ 18 W extra power.

Figure 6 shows the temperature T_4 vs. the input power and the experimental points obtained when the exothermic process was active. We can observe that the *excited state* exists in a wide temperature range. The *excited state* curve becomes nearer to the calibration one when the power is lower, as already shown in ref. [1].

The mean power excess of each cell multiplied by its activity period (278 days for cell A and 319 days for cell B) gives an energy excess of about 900 MJ for cell A and 600 MJ for cell B. Such an energy amount cannot be accounted for any chemical reaction occurring inside the cells.

In conclusion we can say that all data coherently support the evidence of an excess heat produced by the sample when it is in the physical conditions provoked by the annealing and storing in a H₂ atmosphere at high temperature as we have described.

* * *

We wish to thank Prof. G. SALVETTI, Dr. E. TOMBARI, Prof. C. STREMMENOS, Drs. V. PALLESCHI, E. TOGNONI and C. FERRARI for helpful suggestions and discussions.

Special thanks are also due to Prof. R. HABEL, Drs. E. MAJORANA and I. USAI and Ing. M. PIANIGIANI for their collaboration in the initial phase of the experiment.

REFERENCES

- [1] FOCARDI S., HABEL R. and PIANTELLI F., *Nuovo Cimento A*, **107** (1994) 163.
- [2] FOCARDI S., GABBANI V., HABEL R., MONTALBANO V., PIANTELLI F. and VERONESI S., *Status of cold fusion in Italy, IV - Proceedings of Siena Workshop, Siena, 24-25 March 1995*, to be edited by STELLA B..
- [3] FOCARDI S., GABBANI V., MONTALBANO V., PIANTELLI F. and VERONESI S., *Atti Accad. Fisiocritici*, Serie XV, Tomo XV (1996), p. 109-115.
- [4] FOCARDI S., GABBANI V., MONTALBANO V., PIANTELLI F. and VERONESI S., *Asti Workshop on Anomalies in Hydrogen/Deuterium Loaded Metals, Asti, 27-30 November 1997, Conf. Proc. SIF*, Vol. **64** (1999), in press.
- [5] See, for instance, *Proceedings of the 5th International Conference on Cold Fusion, Monte Carlo, Monaco, 9-15 April 1995*, and references therein.
- [6] SANKARANARAYANAN T. K., SRINIVASAN M., BAJPAI M. B., and GUPTA D. S., *Proceedings of the 5th International Conference on Cold Fusion, Monte Carlo, Monaco, 9-15 April 1995*, 1995, p. 173; SHYAM A., SRINIVASAN M., KAUSHIK T. C. and KULKARNI L. V., *Proceedings of the 5th International Conference on Cold Fusion, Monte Carlo, Monaco, 9-15 April 1995*, 1995, p. 181.
- [7] BERTORELLE E., *Trattato di galvanotecnica*, Vol. **1** (Hoepli) 1974.
- [8] FUKAI Y., *The metal-hydrogen system* (Springer-Verlag, Berlin) 1993.
- [9] SCLAPBACH L., *Topics Applied Physics, Hydrogen in intermetallic compounds I*, Vol. **63** (Springer-Verlag, Berlin) 1988.