

Miles, M. and K.B. Johnson, *Anomalous Effects in Deuterated Systems, Final Report*. 1996, Naval Air Warfare Center Weapons Division.

NAWCWPNS TP 8302

# ANOMALOUS EFFECTS IN DEUTERATED SYSTEMS

by

Melvin H. Miles

Benjamin F. Bush

Kendall B. Johnson

Research and Technology Division

SEPTEMBER 1996

NAVAL AIR WARFARE CENTER WEAPONS DIVISION  
CHINA LAKE, CA 93555-6100

REPORT DOCUMENTATION PAGE			Form Approved OMB No. 0704-0188	
Public reporting burden for this collection of information is estimated to average 1 hour per response, including the time for reviewing instructions, searching existing data sources, gathering the data needed, and completing and reviewing the collection of information. Send comments regarding this burden estimate or any other aspect of this collection of information, including suggestions for reducing this burden, to Washington Headquarters Services, Directorate for Information Operations and Reports, 1215 Jefferson Davis Highway, Suite 1204, Arlington, VA 22202-4302, and to the Office of Management and Budget, Paperwork Reduction Project (0704-0188), Washington, DC 20503.				
1. AGENCY USE ONLY (Leave blank)		2. REPORT DATE September 1996	3. REPORT TYPE AND DATES COVERED Final, Jan 92-Sep 95	
4. TITLE AND SUBTITLE <b>Anomalous Effects in Deuterated Systems</b>			5. FUNDING NUMBERS PE 061153N Project R1306 R&T Project Code 313z001srp06	
6. AUTHORS <b>Melvin H. Miles, Benjamin F. Bush, and Kendall B. Johnson</b>			8. PERFORMING ORGANIZATION REPORT NUMBER <b>NAWCWPNS TP 8302</b>	
7. PERFORMING ORGANIZATION NAME(S) AND ADDRESS(ES) <b>Naval Air Warfare Center Weapons Division China Lake, CA 93555-6100</b>			10. SPONSORING/MONITORING AGENCY REPORT NUMBER	
9. SPONSORING/MONITORING AGENCY NAMES(S) AND ADDRESS(ES) <b>Office of Naval Research 800 North Quincy Arlington, VA 22207-5660</b>			10. SPONSORING/MONITORING AGENCY REPORT NUMBER	
11. SUPPLEMENTARY NOTES				
12a. DISTRIBUTION /AVAILABILITY STATEMENT  A Statement; public release; distribution unlimited.			12b. DISTRIBUTION CODE	
13. ABSTRACT (Maximum 200 words) (U) Excess power was measured in 28 out of 94 electrochemical experiments conducted using palladium or palladium-alloy cathodes in heavy water. Reproducibility continues to be the major problem in this controversial research area. Based on our experiments, this lack of reproducibility stems from unknown variables in the palladium metal. The best reproducibility for excess power was obtained using palladium-boron materials supplied by the Naval Research Laboratory. Our basic isoperibolic calorimeters were capable of measuring excess power with a sensitivity of $\pm 1\%$ of the input power or $\pm 20$ mW, whichever was larger. Calorimeters that are capable of detecting excess power levels of 1 watt per cubic centimeter of palladium are essential for research in this field. Results from our laboratory indicate that helium-4 is the missing nuclear product accompanying the excess heat. Thirty out of 33 experiments showed a correlation between either excess power and helium production or no excess power and no excess helium. The collection of the electrolysis gases in both glass and metal flasks place the helium-4 production rate at $10^{11}$ to $10^{12}$ atoms per second per watt of excess power. This is the correct magnitude for typical deuteron fusion reactions that yield helium-4 as a product. Anomalous radiation was detected in some experiments by the use of X-ray films, Geiger-Mueller counters, and by the use of sodium iodide detectors. There was never any significant production of tritium in any of our experiments.				
14. SUBJECT TERMS Calorimetry, Deuterium, Electrolysis, Excess Power, Helium-4, Radiation, Tritium			15. NUMBER OF PAGES <b>98</b>	
			16. PRICE CODE	
17. SECURITY CLASSIFICATION OF REPORT <b>UNCLASSIFIED</b>	18. SECURITY CLASSIFICATION OF THIS PAGE <b>UNCLASSIFIED</b>	19. SECURITY CLASSIFICATION OF ABSTRACT <b>UNCLASSIFIED</b>	20. LIMITATION OF ABSTRACT <b>UL</b>	

## ACKNOWLEDGMENTS

The authors thank D. Miles of the Naval Air Warfare Center Weapons Division (NAWCWPNS) for many helpful computer calculations and data analyses and R. Miles of E. G. and G. Rocky Flats Inc., Golden, Colorado, for expertise concerning radiation. We also express appreciation for American Society for Engineering Education (ASEE), Washington, DC, postdoctoral fellowships for D. Stilwell, K. Park, and G. Ostrom. We especially thank D. Stilwell for investigating various calorimetric techniques in 1989. The authors thank R. Hollins for encouragement and support; J. Fontenot and J. France for financial assistance in obtaining supplies and equipment from 1989 to 1991; and R. Rhein and L. Liedtke for helpful discussions, all from NAWCWPNS. We also thank D. Dominguez, P. Hagans, M. Imam, S. Chubb, T. Chubb, W. O'Grady, and S. King from the Naval Research Laboratory (NRL), Washington, DC; M. Melich from the Naval Postgraduate School, Monterey, California; M. McKubre from SRI International (SRI) Energy Research Center, Menlo Park, California; R. Hart from Hart R and D Inc., Mapleton, Utah; H. Bergeson and S. Barrowes from the University of Utah, Salt Lake City, Utah; and W. Hansen from Utah State University, Logan, Utah, for many helpful discussions. We thank J. Dash of Portland State University, Portland, Oregon; K. Mori of Tanaka Kikinzoku Kogyo K. K., Kanagawa, Japan, for palladium sheet samples; S. Nezu of IMRA Material R and D Co., Ltd. (IMRA), Kariya, Aichi, Japan, for the loan of a palladium-silver alloy; and M. Imam of NRL for the palladium-boron alloys. We also thank M. Fleischmann and S. Pons of IMRA Europe, Valbonne, France, for the loan of electrode materials as well as helpful discussions. Special appreciation is extended to the Office of Naval Research (ONR) for support of this work, and to D. Nagel of NRL for providing the funding to publish this report.

Naval Air Warfare Center Weapons Division

This work was funded by the Office of Naval Research (ONR) as a collaborative program with the Naval Research Laboratory (NRL) and the Naval Command, Control and Ocean Surveillance Center-Naval Research and Development (NCCOSC-NRaD). This is the final report of the research performed at the Naval Air Warfare Center Weapons Division (NAWCWPNS) on anomalous effects involving deuterated palladium and palladium alloys. This report examines the possible production of excess power, helium-4, tritium, and radiation during the electrolysis of heavy water (D<sub>2</sub>O) using palladium and palladium alloys as cathodes.

This report describes work supported by the Office of Naval Research and has been reviewed for technical accuracy by Richard A. Hollins and John D. Stenger-Smith.

Approved by  
R. L. DERR, *Head*  
*Research & Technology Division*  
18 September 1996

Under authority of  
J. CHENEVEY  
Capt., U.S. Navy  
*Commander*

Released for publication by  
S. HAALAND  
*Director for Research & Engineering*

NAWCWPNS Technical Publication 8302

Published by .....Scientific and Technical Documentation  
Collation ..... Cover, 50 leaves  
First printing .....280 copies

## ABSTRACT

Excess power was measured in 28 out of 94 electrochemical experiments conducted using palladium or palladium-alloy cathodes in heavy water. Reproducibility continues to be the major problem in this controversial research area. Based on our experiments, this lack of reproducibility stems from unknown variables in the palladium metal. The best reproducibility for excess power was obtained using palladium-boron materials supplied by the Naval Research Laboratory. Our basic isoperibolic calorimeters were capable of measuring excess power with a sensitivity of  $\pm 1\%$  of the input power or  $\pm 20$  mW, whichever was larger. Calorimeters that are capable of detecting excess power levels of 1 watt per cubic centimeter of palladium are essential for research in this field. Results from our laboratory indicate that helium-4 is the missing nuclear product accompanying the excess heat. Thirty out of 33 experiments showed a correlation between either excess power and helium production or no excess power and no excess helium. The collection of the electrolysis gases in both glass and metal flasks place the helium production rate at  $10^{11}$  to  $10^{12}$  atoms per second per watt of excess power. This is the correct magnitude for typical deuteron fusion reactions that yield helium-4 as a product. Anomalous radiation was detected in some experiments by the use of X-ray films, Geiger-Mueller counters, and by the use of sodium iodide detectors. There was never any significant production of tritium in any of our experiments.

# CONTENTS

ABSTRACT .....	5
CONTENTS .....	6
EXECUTIVE SUMMARY .....	7
INTRODUCTION .....	8
CHINA LAKE CALORIMETRY .....	10
IMPROVED CHINA LAKE CALORIMETRY .....	13
CHINA LAKE RESULTS PRIOR TO 1992 .....	14
HEAT AND HELIUM PRODUCTION .....	17
CO-DEPOSITION EXPERIMENTS IN 1992 .....	21
RADIATION MEASUREMENTS .....	23
TRITIUM MEASUREMENTS .....	25
NRL MATERIALS: Pd-Ag ALLOY STUDIES .....	27
NRL MATERIALS: Pd CATHODE STUDIES .....	28
OTHER CATHODE MATERIALS: NO EXCESS HEAT .....	29
OTHER CATHODE MATERIALS PRODUCING EXCESS HEAT .....	30
USE OF ADDITIVES .....	31
HEAT AND HELIUM STUDIES USING METAL FLASKS .....	31
MISCELLANEOUS HELIUM MEASUREMENTS .....	35
NRL PALLADIUM-BORON MATERIALS .....	36
PALLADIUM WIRE STUDIES .....	39
SUGGESTED PROCEDURES FOR EXCESS-HEAT PRODUCTION .....	41
DISCUSSION .....	42
SUMMARY .....	47
REFERENCES .....	48
FIGURES .....	52
APPENDIXES .....	87
Appendix A. TEMPERATURE-DEPENDENT CALORIMETRIC PARAMETERS .....	87
Appendix B. ROOM TEMPERATURE CORRECTION .....	88
Appendix C. PROBABILITIES OF EXPERIMENTAL HEAT AND HELIUM CORRELATIONS .....	89

## EXECUTIVE SUMMARY

Our results provide compelling evidence that the anomalous effects in deuterated systems are real. Nevertheless, we have not been able to solve the reproducibility problem. This research area will remain highly controversial until reproducibility can be demonstrated. The lack of reproducibility stems mainly from unknown and uncontrolled variables in the palladium stock. There is a remarkable correlation of excess power with the source of the palladium. The best reproducibility was obtained using palladium-boron (Pd-B) materials supplied by the Naval Research Laboratory (NRL), Washington, DC. Seven out of eight experiments that used Pd-B cathodes produced excess power. In experiments that used the palladium from Johnson-Matthey, 17 of 28 experiments produced excess heat. In contrast there were several palladium sources that never produced excess power in any experiment. Our calorimetric results, conclusions, and problems are practically identical to those reported by the SRI International (SRI) Energy Research Center, Menlo Park, California. They are also consistent with many other laboratories that have reported excess heat. Calorimeters that are capable of detecting excess power levels of 1 watt per cubic centimeter ( $\text{W}/\text{cm}^3$ ) of palladium are essential for research in this field. The small volume of palladium in co-deposition experiments likely made it difficult to detect excess power effects.

Results from our laboratory indicate that helium-4 ( $^4\text{He}$  is used interchangeably with helium-4) is the missing nuclear product. Thirty experiments have shown a correlation between either excess power and helium production or no excess power and no excess helium. Studies using both glass and metal flasks place the  $^4\text{He}$  production rate at  $10^{11}$  to  $10^{12}$  atoms per second per watt ( $\text{atoms}/\text{s} * \text{W}$ ) of excess power. This is the correct magnitude for typical deuteron fusion reactions that yield helium as a product. It is highly unlikely that our heat and helium correlations could be due to random errors. The only valid experiments that showed significant excess power but no excess helium involved a palladium-cerium (Pd-Ce) cathode.

Our best experiments produced up to 30% excess heat, 0.52 watts of excess power, and 1400 kilojoules (kJ) of excess enthalpy. This amount of excess enthalpy is difficult to explain by any chemical reaction. We have demonstrated that any recombination of the deuterium ( $\text{D}_2$ ) and oxygen ( $\text{O}_2$ ) electrolysis gases in our experiments can be readily detected and easily corrected. There was never any measurable recombination when the palladium cathodes were fully submerged in the deuterium oxide plus deuterated lithium hydroxide ( $\text{D}_2\text{O} + \text{LiOD}$ ) electrolyte.

Anomalous radiation was detected in some experiments by the use of X-ray films, several different types of Geiger-Mueller (GM) counters, and sodium iodide (NaI) detectors. Normal radiation counts were always observed when no electrolysis experiments were running. The appearance of anomalous radiation always correlated with the expected rate of loading of the palladium with deuterium. Nevertheless, the anomalous radiation effect was not reproducible.

There was never any significant production of tritium in any of our experiments. A few experiments, however, suggested low levels of tritium production.

## INTRODUCTION

This Office of Naval Research (ONR)-sponsored program began in January of 1992, involving the Naval Air Warfare Center Weapons Division (NAWCWPNS, formerly Naval Weapons Center (NWC)), Naval Command, Control and Ocean Surveillance Center-Naval Research and Development (NCCOSC-NRaD), San Diego, California (formerly Naval Ocean Surveillance Center (NOSC)), and the Naval Research Laboratory (NRL), Washington, DC. However, there was considerable research on this topic conducted at China Lake prior to 1992. This research will be summarized in this report. A considerable portion of the China Lake results has been published in refereed scientific journals and conference proceedings. These published results will be briefly summarized and referenced; copies of these articles are available from the author.

The objective of this program was to answer two basic questions:

1. Is the apparent physical effect real?
2. If so, can it be reproduced regularly?

In our opinion, the answer to the first question, based on this research, is yes, but the answer to the second question is no. The lack of reproducibility has made this research exceedingly difficult and frustrating. The only consolation is that no other research group in the world has been able to solve the reproducibility problem. Given that the excess heat effect is real, this will never be a useful energy source until the reproducibility problem is solved.

Most scientists hold the view that anomalous effects in deuterated metals can be explained by experimental errors. Some scientists go so far as attributing positive results to self-deception and even fraud and consign this phenomena to the realms of Langmuir's "Pathological Science." Due to the lack of experimental reproducibility, this field remains practically defenseless against such attacks. To our knowledge, no laboratory can provide detailed experimental instructions to another laboratory and guarantee the reproduction of the excess heat effect. Nevertheless, considerable knowledge has been gained concerning experimental conditions that favor the excess heat effect. Later in this report, we will provide a detailed description of procedures, based on our experiments, that favor the anomalous production of excess power. However, our experiments indicate that the lack of reproducibility is due largely to unknown and uncontrolled variables contained within the palladium stock. Studies by M. McKubre et al. at SRI have led to this same conclusion (Reference 1).

Many scientists attribute reports of excess power production in these experiments to calorimetric errors. However, it is nearly impossible to explain how calorimetric errors could lead to practically identical results between independent laboratories. For example, the major conclusions from the China Lake calorimetric experiments are almost identical to those reported by M. McKubre et al. at SRI (References 1 and 2). The excess power measurements in the China Lake experiments can be summarized by the following conclusions:

1. The excess power effect is typically 5 to 10% larger than the input power. The largest excess power effect was 30%.
2. The excess power in terms of the palladium volume typically yields 1 to 5 W/cm<sup>3</sup>.
3. Long electrolysis times are required before the onset of the excess power effect. This time period usually ranges from 6 to 14 days of electrolysis.
4. Excess power production requires a threshold current density of 100 milliamperes per square centimeter (mA/cm<sup>2</sup>) or larger.
5. Most experiments produced no evidence of any excess power. Overall, only 30% of our experiments yielded evidence for excess power.
6. Our success ratio in obtaining excess power varied greatly with the source and batch of palladium used.

The SRI results typically yielded 5 to 10% excess power with a maximum of 28% excess power; the excess power in terms of the palladium volume was 1-5 W/cm<sup>3</sup> on the average; the initiation time was on the order of 300 hours (h) for 1- to 4-millimeter (mm) diameter Pd wires; the threshold current density ranged from 100 to 400 mA/cm<sup>2</sup>; and the success rate varied greatly with the source of the palladium (References 1 and 2). This striking agreement between the China Lake and SRI results simply cannot be explained by calorimetric errors. Furthermore, the calorimeters used at China Lake and SRI are totally different. China Lake used an open, isoperibolic calorimetric system (References 3 and 4) while SRI employed a closed, isothermal flow calorimetric design (Reference 2).

The China Lake calorimetric results are also very similar to those reported by M. Fleischmann et al. (Reference 5) when the excess power density (W/cm<sup>3</sup>) in terms of the palladium volume is compared with the experimental current density. Both China Lake and M. Fleischmann (Reference 5) report approximately 1 W/cm<sup>3</sup> of palladium at current densities of 100 to 200 mA/cm<sup>2</sup> (see Figure 4 of Reference 6). In a review by E. Storms (Reference 7), the China Lake calorimetric excess heat effects are shown to be very similar to those reported by many other laboratories.

The calorimetric results reported by China Lake have been used to support both sides of the scientific controversy regarding anomalous effects in deuterated metals. Our first set of experiments conducted over a 6-month period (25 March-7 September 1989) produced no significant evidence for any excess enthalpy production (Reference 3). These early experiments at China Lake were listed in the Energy Research Advisory Board (ERAB) report to the U.S. Department of Energy as one of the groups not observing excess heat (Reference 8). The groups from Massachusetts Institute of Technology (MIT), Cambridge, Massachusetts; California Institute of Technology (CalTech), Pasadena, California; and Harwell Laboratory, Oxfordshire, United Kingdom, also reported no evidence for excess heat (Reference 8), thus greatly impacting

the general scientific opinion regarding this field. All three groups discontinued their experiments after only a few months of investigation. We continued to investigate other palladium samples and eventually observed significant evidence for excess enthalpy from the use of Johnson-Matthey palladium rods (References 4 and 9). In retrospect, it would be impossible for any research group to adequately investigate the multitude of variables involved with this field in only a few months. These variables range from the palladium metallurgy to the D<sub>2</sub>O purity, the type of electrolyte and concentration, the electrochemical cell, the electrode arrangement, the type of calorimeter, proper scaling of the experiments, the handling of materials, the current densities used, the duration of the experiments, the loading of deuterium into the palladium, the use of additives, and so on. The investigation of some of these variables has been reported by McKubre et al. (References 1, 2, and 10). We will discuss our conclusions regarding many of these experimental variables in this report.

## CHINA LAKE CALORIMETRY

Our measurements of excess power that will be presented in this report will not be accepted by other scientists until they are convinced that the calorimetric measurements are correct. This problem is compounded by recent publications by S. E. Jones et al. (References 11 and 12) that attack claims of excess heat production in “cold fusion” experiments. This attack features a detailed examination of publications from our laboratory (Reference 11). We will refute many of the issues raised by Jones regarding our work in this report. A response has been submitted to the Journal of Physical Chemistry.

Considerable progress has been made in our understanding of calorimetric principles and problems since our initial studies in 1989. Our present understanding of open, isoperibolic calorimetry involving the electrolysis of D<sub>2</sub>O + LiOD is detailed in a recent publication (Reference 13). There is no steady state in these experiments since D<sub>2</sub>, O<sub>2</sub>, and D<sub>2</sub>O vapor continually exit the cell in the gas stream; thus the LiOD concentration steadily increases and the cell voltage decreases (see Figure 2 of Reference 13). The addition of D<sub>2</sub>O to replenish the amount lost by electrolysis and evaporation is generally made at the end of the day.

The equation governing the time-dependent behavior of our calorimeter can be expressed as

$$(E(t) - \gamma E_H)I + P_x = a + K\Delta T + P_{gas} + P_{calor} \quad (1)$$

where P<sub>x</sub> represents any excess power (Reference 13). The rate of enthalpy transfer outside the cell due to the D<sub>2</sub>, O<sub>2</sub>, and D<sub>2</sub>O gas stream (P<sub>gas</sub>) is given by

$$P_{gas} = \frac{\gamma I}{F} \left\{ \left[ 0.5C_{P,D_2} + 0.25C_{P,O_2} + 0.75 \left( \frac{P}{P^* - P} \right) C_{P,D_2O(v)} \right] \Delta T + 0.75 \left( \frac{P}{P^* - P} \right) L \right\} \quad (2)$$

and the time dependence of the enthalpy of the calorimeter is given by

$$P_{calor} = C_{P,D_2O(l)} \left[ M^\circ - (1 + \beta) \frac{\gamma I t}{2F} \right] d\Delta T / dt - (1 + \beta) \frac{\gamma I}{2F} C_{P,D_2O(l)} \Delta T \quad (3)$$

The symbols in these equations are defined in Reference 13. These expressions are essentially the same as those reported by Fleischmann et al. (Reference 5). The current efficiency for D<sub>2</sub>O electrolysis ( $\gamma$ ) was always determined to substantiate any measurements of excess power (Reference 14), thus claims by Jones et al. (References 11 and 12) that recombination of D<sub>2</sub> and O<sub>2</sub> gases within the electrochemical cell can explain the excess heat production are without foundation.

Equations 1 through 3 are actually much more complicated than they appear since the treat capacities ( $C_P$  D<sub>2</sub>,  $C_P$  O<sub>2</sub>,  $C_P$ , D<sub>2</sub>O (V)), the partial vapor pressure of the D<sub>2</sub>O solution (P), the enthalpy of evaporation for D<sub>2</sub>O (L), and the thermoneutral potential (AH) are expressed as empirical equations that define their numerical values over the experimental temperature range. These empirical equations used in our calculations are given in Appendix A. Our calculations, therefore, are based on the actual cell temperature rather than on some arbitrary standard state temperature. Equation 1 becomes a complicated, nonlinear, inhomogeneous differential equation when the time-dependent expressions for  $P_{gas}$  and  $P_{calor}$  are incorporated (Reference 13).

We have presented a critical analysis for the key calorimetric publications from CalTech, MIT, and Harwell based on our Equations 1 through 3 (Reference 13). Despite the fact that it was the calorimetric results from CalTech, MIT, and Harwell that convinced most scientists that the excess power effect did not exist, nobody has challenged the validity of our Equations 1 through 3. All three of these major laboratories that reported no excess power assumed steady state conditions for their electrolysis experiments and incorrectly defined the cell output power simply by  $K\Delta T$  (Reference 13). In fact, our analysis of the CalTech calorimetric results indicates excess power as large as 76 milliwatt (mW) at 140 mA/cm<sup>2</sup> (Reference 13). This corresponds to 1.0 W/cm<sup>3</sup> of palladium and is in excellent agreement with our results.

As pointed out by Jones and Hansen (Reference 11), we have also used simplified calorimetric expressions in some of our early publications (References 3 and 4). Although  $P_{gas}$  and  $P_{calor}$  vary significantly with current (I) and the electrolyte concentration, their sum remains positive and less than 0.020 W for our range of experimental conditions. Therefore, neglecting the sum  $P_{gas} + P_{calor}$  in Equation 1 will only underestimate our value for  $P_x$  (Reference 13). This conclusion may not be valid for other designs of isoperibolic calorimeters. Our calorimeters are unusual due to an outer water jacket that surrounds the cell and acts as an integrator of the heat output of the cell (References 3 and 4).

As should be expected, our calorimetry has improved with time. An early version had glass tubes containing the thermistors that protruded considerably above the tops of the cells (Reference 4). Although the effect of these thermistor tubes was not apparent when the room temperature was stable, cooler weather later produced greater fluctuations in room temperature and unstable thermistor readings. This was especially apparent in a water (H<sub>2</sub>O) control study (Figure 6 of Reference 4). In the following experiments, the thermistor tubes were made flush

with the cell top, resulting in much more uniform measurements. Although Jones and Hansen (Reference 11) focused considerable attention on Figure 6 of Reference 4, they ignored our explanation and correction for this effect (see pp. 245-246 of Reference 4). A dramatic improvement in the calorimetric stability is seen in the experiment following the H<sub>2</sub>O control study (see Figure 7 of Reference 4) where the single-tail t test for excess enthalpy easily exceeds the 99.95% confidence level (see Table 2 of Reference 4).

A major error source for our calorimetry is the flow of heat out of the top of the cell that is affected by the room temperature (Reference 13). At constant bath (27.50°C) and room temperature (23.50°C), it can be shown that the flow of power from the cell to the room and to the bath is given by

$$P = K_i(T_b - T_R) + K\Delta T = a + K\Delta T \quad (4)$$

where  $K = K_b + K_i$  (References 13 and 14). From experimental evaluations of  $K_i$  and  $K$ , it can be shown that a  $\pm 1.0^\circ\text{C}$  change in room temperature produces a  $\pm 20$  mW error in our calorimetric measurements. A theoretical correction for changes in either the room ( $T_R$ ) or bath ( $T_b$ ) temperatures is given by

$$\Delta T = \Delta T_{\text{obs}} + K_i K^{-1}(T_b - T_R - 4) \quad (5)$$

where  $\Delta T_{\text{obs}}$  is the observed difference between the cell and bath temperatures. For calorimetric cells A and B,  $K_i K^{-1}$  is experimentally determined to be 0.15 while for calorimetric cells C and D that use insulated caps,  $K_i K^{-1}$  is 0.05. From Equation 5, a  $\pm 1^\circ\text{C}$  change in  $T_b - T_R$  produces a  $\pm 0.15^\circ\text{C}$  error in  $\Delta T_{\text{obs}}$  for cells A and B. For a cell constant ( $K$ ) of 0.14 W/ $^\circ\text{C}$ , the  $\pm 0.15^\circ\text{C}$  error in  $\Delta T$  provides an error of  $\pm 0.021$  W using  $P = K\Delta T$ . All calculations involving Equations 1 through 3 also involved the correction expressed by Equation 5. The deviation of Equation 5 is given in Appendix B. Except for seasonal changes in our heating and cooling system, our laboratory room temperature was generally maintained within  $\pm 1^\circ\text{C}$  of 23.5°C.

Accurate calorimetry requires extensive averaging of the cell potential,  $E(t)$ , which fluctuates due to the evolution of gas bubbles from both the anode and cathode surfaces. These voltage fluctuations were generally about  $\pm 0.1$  volt (V), but this varied with the current, electrolyte type and concentration, cell geometry, electrode arrangement, and any solution foaming problems. We continuously monitored the cell potentials using strip chart recorders and averaged the voltage over approximately a 10-minute (min) interval during measurements. Calibrations were always performed exactly the same as other measurements to minimize errors. Due to the time constants of our calorimeters (25 to 30 min, see Reference 14),  $\Delta T$  in Equation 1 was also a corresponding time-averaged measurement. The averaged cell potentials were generally measurable to within  $\pm 0.01$  V or  $\pm 0.5\%$ , whichever was larger.

The accuracy of our calorimetry is illustrated in Figure 1 that features an experiment that never displayed any evidence for excess power. The measured output power ( $a + K\Delta T + P_{\text{gas}} + \text{Pastor}$ ) tracks very closely to the electrochemical input power as expressed in Equation 1. Another experiment that produced no excess power is displayed in Figure 2. The ratio,  $X$ , of output power

and input power calculated from Equation 1 remains close to unity. Approximately 70% of our experiments displayed no evidence for excess power and served as controls for our calorimetry.

The use of Equations 1 through 3 along with the room temperature correction (Equation 5) yields an error range of  $\pm 20$  mW or  $\pm 1\%$  of the input power (whichever is larger) for our isoperibolic calorimetry. This compares favorably with the SRI flow calorimetry where excess power below 50 mW is judged to be indiscernible (Reference 1). The noise level in the SRI calorimetry is generally  $\pm 95$  mW (References 1 and 2). Initially, in developing our calorimetry, we concluded that excess power effects below about 50 mW would not be of interest. However, more accurate calorimetry is required in measuring small power effects related to the loading of deuterium into the palladium and in examining events that trigger or kill small excess power effects. An improved calorimeter recently developed at China Lake that can accomplish these tasks is described in the next section.

In June of 1995, Roger M. Hart, founder of Hart R and D Inc., Mapleton, Utah, and an expert in the design, construction, and testing of calorimeters, visited our laboratory at China Lake. After carefully examining our calorimetric design and techniques, he agreed with our stated error range of  $\pm 20$  mW or  $\pm 1\%$  of the input power, whichever is larger. This is especially true over our normal operating temperature range of 40 to 60°C for the cell temperatures. At higher temperatures, nonlinear effects such as heat transported by radiation become larger. The  $P_{\text{gas}}$  term (Equation 3) also rapidly becomes larger at high cell temperatures due mainly to increased evaporation of D<sub>2</sub>O. The effect of the cell temperature on the  $P_{\text{gas}}$  term is shown in Figure 3. Furthermore, the loss of H<sub>2</sub>O from the integrating jacket becomes a problem at high cell temperatures. At low cell temperature, the fraction of heat lost through the top of the cell becomes larger (see Equation 4). This becomes especially noticeable for cell power levels below 0.6 W (see Figure 5 of Reference 13).

A major criticism presented by Jones and Hansen (Reference 11) of our calorimetry is the variation of the calorimetric cell constants over various experiments. For example,  $K_1$  ranges from 0.135 to 0.141 W/°C over four separate experiments that yield a mean of  $0.138 \pm 0.003$  W/°C (Reference 4). Roger Hart pointed out that this criticism by Jones and Hansen is not valid since all cell components are repositioned in each experiment. The relative positions of the anode and cathode electrodes and of the two thermistors vary somewhat with each new cell assembly, thus the slight variation in the calorimetric cell constants in different experiments is expected.

## **IMPROVED CHINA LAKE CALORIMETRY**

Based on our previous experience with integrating open, isoperibolic calorimeters, improvements were recently made to eliminate most of the error sources. This new calorimetry and improvements are illustrated in Figure 4. The major new improvements include a copper (Cu) inner jacket that acts as the integrator and replaces the H<sub>2</sub>O jacket. An insulating box over the cell top and bath greatly reduces the effect of changes in the room temperature. Furthermore, the lead wires coming out of the cell are thermally staked to the bath itself, thereby further reducing the effect of the room temperature. A copper outer jacket contacts the bath and minimizes bath level

effects by virtue of its high-thermal conductivity. Foam insulation is used between the two copper jackets. Active cooling of the bath provides excellent temperature stability even at high-input power to the cell.

Perhaps the major improvement is the data acquisition system used with this new cell design. This provides extensive averaging of the cell voltage, cell temperature, and all other readings that are then compiled into a measurement every 5 minutes. This steady collection of data provides for the tracking of events that may trigger the excess power effect. Two calorimeters of this improved type are run in series, and six experiments were completed. This new calorimeter yields accurate results for cell temperatures ranging from the bath temperature to near boiling temperatures. This significantly extends the operating cell temperature range of 40 to 60°C for our previous calorimetry.

The ability of this new calorimeter to measure the heat of absorption of deuterium into palladium is shown in Figure 5. A power output of approximately 6.5 mW is observed for 2 hours. This yields 47 J that compares very favorably to the expected 44 J based on the cathode size (1 mm × 4.3 cm), a loading level of PdD<sub>0.6</sub>, and using the reported value of - 35,100 joules/mole (J/mol) D<sub>2</sub> (Reference 14).

The noise level for this improved calorimeter is only ±0.2 mW or ±0.1% of the input power, whichever is larger. This is considerably better than any other electrochemical calorimetric design that we have seen. For comparison, the noise level in the SRI experiments using flow calorimetry is ±25 mW (References 1 and 2). The absolute accuracy as determined from silver cathode control experiments is ±1% or ±10 mW (whichever is larger) over the entire temperature range covering 0 to 5 W of input power.

Examples of several small episodes of excess power from a palladium cathode used in this improved calorimeter will be presented later in this report. Apparently, this new calorimetry can be used to study events that may trigger or kill the excess power effect. A patent application is being prepared based on this new calorimeter design.

## **CHINA LAKE RESULTS PRIOR TO 1992**

Results from our laboratory from 1989 to 1992 are documented in the literature, hence they will be only briefly summarized in this report. Initially, no excess heat was observed in various experiments, but excess heat was eventually measured in later experiments when another source of palladium was tested.

Our early studies in this field were mainly a learning experience. No excess heat effects were observed over the time period of March to September of 1989 (Reference 3). In retrospect, many errors were made that minimized our opportunities for observing any anomalous effects. Similar learning-experience errors were likely at CalTech, MIT, Harwell, and other laboratories that reported no excess heat for their 1989 experiments. The major error was that most of our experiments were simply not run long enough to expect an initiation of the excess power effect.

Furthermore, the palladium used was from a single source (Wesgo) and of unknown purity. Our calorimetry results are listed in the November 1989 report of the Energy Research Advisory Board to the U.S. Department of Energy that evaluated early cold fusion research (Reference 8). We are listed with MIT, CalTech, Harwell, and other laboratories as groups not observing excess heat. Our best set of measurements yielded an average ratio of power out to input power of  $X = 1.00 \pm 0.04$  (Reference 3). Critics of this field cannot accept these early results from our laboratory and then simply reject or ignore our later calorimetric reports of experiments producing excess power.

Between September 1989 and March 1990, five out of six Pd-D<sub>2</sub>O + LiOD experiments produced statistically significant amounts of excess enthalpy (References 4 and 9). The same two palladium rods (Johnson-Matthey) were used in each experiment. Two Pd-H<sub>2</sub>O + lithium hydroxide (LiOH) control studies that used these same cathodes failed to produce the excess heat effect (References 4 and 9). These H<sub>2</sub>O control studies were conducted between the second and third set of experiments in D<sub>2</sub>O + LiOD that produced excess power. The H<sub>2</sub>O studies ended on 25 December 1989, and the palladium cathodes were idle until the next D<sub>2</sub>O + LiOD experiments began on 8 February 1990. Hydrogen contamination of the palladium was apparently not a problem since excess power was again observed for both cathodes after a few days of electrolysis (see Figure 7 of Reference 3). Results were internally much more consistent for these two experiments than observed in the H<sub>2</sub>O studies since the thermistor tubes were now flush with the cell tops (Reference 4). The highest confidence levels for excess enthalpy using the single-tail t test were obtained in this third set of Pd-D<sub>2</sub>O + LiOD experiments (see Table 2 of Reference 4). The excess enthalpy easily exceeded the 99.95% confidence level (Reference 4).

Some comments on the Pd-D<sub>2</sub>O + LiOD experiments conducted between September 1989 and March 1990 may be useful since these studies yielded one of our highest success rates for excess enthalpy production. The following experimental conditions may have been important in obtaining the excess heat effect:

1. The same two palladium cathodes were used in each set of experiments. This supports the concept that the palladium metallurgy is a critical variable. Furthermore, heat-producing cathodes can be successfully reused in following experiments.
2. One palladium cathode failed to produce statistically significant excess heat in its first experiment, but excess heat was observed in the second and third D<sub>2</sub>O-LiOD experiments using this cathode. This suggests that the loading and deloading of the palladium with deuterium may help to induce the excess heat effect.
3. The connection between the palladium cathode and the nickel lead wire was always made by spot welding. Solder was rarely used in our experiments.
4. The nickel lead wire used for the cathode was covered with heat-shrinkable Teflon tubing, and the spot weld was masked with clear epoxy (Epoxi-patch No. 0151). This minimized any direct contact of nickel with the solution. Furthermore, this nickel wire was under cathodic protection during these experiments. McKubre et al. (Reference 1) report a strong, deleterious effect on loading when nickel is used as the anode.

5. The anodes were constructed completely of platinum (Pt)-20% Rh. No other leads were connected. Platinum is generally used as anodes and for connections to the Pd cathodes in these experiments, but we did not have Pt wire of the required diameter (0.1 cm) available at the time.
6. The electrochemical cells were washed thoroughly using Alconox detergent and then rinsed with copious amounts of water and distilled water. No acetone or other organic solvents were used. These cells were always placed in a vacuum oven overnight or longer prior to use.
7. The electrolysis cells were not sealed, hence the gases vented directly into the atmosphere. Rubber stoppers were always used for the cell tops. In later experiments involving helium analysis, the cells were sealed with silicon rubber and the gases were vented through an oil bubbler. There may have been contamination from both the silicon rubber and the mineral oil in the bubbler. It may have been better to have vented the gases through a D<sub>2</sub>O bubbler and then through the oil bubbler. Sealing the cells minimized H<sub>2</sub>O and carbon dioxide (CO<sub>2</sub>) contamination from the atmosphere but may have added acetic acid and other species from the silicon rubber.
8. The same lot of D<sub>2</sub>O was used in these experiments (Cambridge Isotopes, 99.9% D). Later experiments that used a new lot of D<sub>2</sub>O were less successful despite the use of cathodes cut from the same palladium rod.
9. The same lithium source (ROC/RIC, 99.95%) was used in making up the 0.1 molar (M) LiOD solutions. These solutions were prepared a few days prior to the start of the experiments and stored in brown glass bottles (empty D<sub>2</sub>O bottles).
10. A current of 264 mA was switched between anodic and cathodic polarities about 10 times over a 20-minute period prior to starting the experiments.
11. A cathodic current density of 100 mA/cm<sup>2</sup> (264 mA) was applied from the beginning and throughout the experiment.

Since these experiments later became much less reproducible, it has been impossible to unravel the importance of each experimental variable. Nevertheless, it is our opinion that the selection of the palladium cathode material is the most critical step. Nothing else seems to matter if the palladium cathode material is not suitable. Exactly what constitutes a suitable palladium material remains to be defined. The absence of cracks, surface inclusions, and damage is apparently important (Reference 1). The grain size of the palladium and the presence of impurities, such as boron, may also be important.

Except for calorimetric calibration studies, no further experiments were conducted involving this topic until October 1990. The objectives of these new experiments were to determine if helium is produced during excess heat events, to test for neutron activation of gold and indium foils, and to investigate higher current densities (200 to 250 mA/cm<sup>2</sup>). These experiments in calorimetric cells A and B used the same two palladium cathodes as before, but the LiOD concentration was increased to 0.2 M to accommodate the higher currents. Nevertheless, the

current density was set at 100 mA/cm<sup>2</sup> at the beginning and ranged from 50 to 100 mA/cm<sup>2</sup> for the first 12 days of the experiment. Normal calorimetric behavior was observed during this period, and no excess heat was detected. There was no evidence for any energy storage mechanism as suspected by Jones and Hansen (Reference 11). Excess power became apparent in cell B at 13 days and in cell A after 18 days of electrolysis (see Figure 3 of Reference 14). Including this study, these two palladium cathodes yielded excess heat in seven out of eight experiments. One cathode had a perfect four out of four record for excess enthalpy production. These palladium cathodes were once again used in H<sub>2</sub>O control experiments that yielded no significant levels of excess heat and were later sectioned into small pieces to determine the helium content within the palladium (Reference 14). Therefore, no further calorimetric experiments were possible for these cathodes.

## HEAT AND HELIUM PRODUCTION

A major conclusion of the final D<sub>2</sub>O + LiOD experiments involving these special heat-producing palladium cathodes is that helium-4 production is associated with the excess heat events. These experiments began 3 October 1990 and ended 25 December 1990. This correlation of excess power and helium production during D<sub>2</sub>O electrolysis is discussed in several publications (References 6 and 14 through 17). Our largest excess power effect (0.52 W) in any experiment was obtained in this study at a current density of 250 mA/cm<sup>2</sup> (References 14 and 15). Based on these experiments helium-4 was the major product rather than helium-3 (Reference 15). Any production of helium-3 was below our detection limit. No activation of iridium or gold foils was detected in this study, hence the average neutron emission rates were less than 10<sup>5</sup> s<sup>-1</sup> (References 14 and 18). However, the exposure of dental X-ray films placed close to the cells suggested the emission of radiation (Reference 14). More than 20 similar tests involving X-ray films conducted in later experiments failed to show any significant exposure of such films.

The production of helium-4 in these experiments is a very difficult concept to prove since there is always the possibility of atmospheric helium contamination (Reference 11). More studies reporting helium-4 production will likely be required before our helium results become convincing to most scientists. In retrospect, helium-4 is probably the only nuclear product that could have remained so well hidden from view over the past 7 years of experiments. Energetic particles, penetrating radiation, or radioactive isotopes would be more readily detectable products. It is interesting to note that several theories, including that of Chubb and Chubb of NRL (Reference 19), predicted helium as a major product prior to our experiments, and predicted that this product would reside mainly in the electrolysis gas stream. The analysis of palladium samples cut from the same rod that were never subjected to electrolysis yielded helium levels too small to explain the helium production in our experiments (Reference 14). Samples of our heat-producing palladium cathodes used in the D<sub>2</sub>O + LiOD studies were also analyzed but failed to show any significant levels of helium-3 or helium-4 (Reference 14). These results, however, are somewhat compromised by the fact that these electrodes were repolished and then used in a following H<sub>2</sub>O + LiOH study prior to cutting samples for analysis (Reference 14). These experiments suggest that helium-4 is produced at or near the surface of the palladium electrode and resides in the electrolysis gas (Reference 14) in agreement with the theoretical predictions of Chubb and Chubb

(Reference 19).

Our initial report of helium production during D<sub>2</sub>O electrolysis was published in March 1991 (Reference 15). A major concern and criticism of these results expressed in 1991 (References 20 and 21) and continuing today (Reference 11) is the possibility of atmospheric helium-4 contamination, especially due to the known diffusion of helium through glass. It was precisely because of these concerns that we conducted control experiments performed exactly the same but using H<sub>2</sub>O + LiOH in place of D<sub>2</sub>O + LiOD.

These control studies gave no evidence for helium-4 production (References 14 through 16). Our first D<sub>2</sub>O + LiOD electrolysis gas sample (10/17/90-A) also served as a control since there was no significant excess heat and no helium-4 detected (References 14 through 16). Our controls, therefore, cover time periods both before and after the excess heat experiments; this is contrary to the suggestion by Jones and Hansen (Reference 11) that we were simply getting better at keeping out helium-4.

The diffusion of atmosphere helium into our Pyrex glass flasks used to collect electrolysis gas samples is certainly a valid concern. Theoretical calculations based on the area (314 cm<sup>2</sup>) and thickness (1.8 mm) of these flasks yields a diffusion rate of  $2.6 \times 10^{12}$  helium atoms per day from the atmosphere into the flask (References 14 and 22). Since our initial helium-4 detection limit was estimated at  $10^{12}$  <sup>4</sup>He atoms/500 milliliters (mL) (References 14 through 16), helium-4 should have been detectable in every sample and in every control. As a possible explanation for this discrepancy, we proposed that the much larger amount of deuterium or hydrogen diffusing out of the glass flask may hinder the inward diffusion of atmospheric helium (References 6, 14, and 16). Although the experimental helium diffusion rates measured for our flasks were always lower for H<sub>2</sub> and D<sub>2</sub>+ O<sub>2</sub>-filled flasks than observed for N<sub>2</sub>-filled flasks (Reference 22), the difference was not large enough to explain our failure to detect helium-4 in every flask. One H<sub>2</sub> and three D<sub>2</sub> + O<sub>2</sub>-filled flasks yielded a mean helium diffusion rate of  $1.9 \pm 0.3 \times 10^{12}$  atoms/day, while three N<sub>2</sub>-filled flasks gave a mean helium diffusion rate of  $3.2 \pm 0.6 \times 10^{12}$  atoms/day (Reference 22). This latter experimental rate is in good agreement with the rate of  $2.6 \times 10^{12}$  atoms/day that was calculated theoretically for our flasks (Reference 22). Based on the experimental diffusion rates of atmospheric helium into our flasks, it was obvious that our reported helium-4 detection limit of  $10^{12}$  atoms/500 mL was too small.

Our initial helium-4 detection limit was based on measurements performed in the chemistry laboratory at the University of Texas, Austin, Texas, where 10 millitorr (mtorr) of air in 500 mL of nitrogen (N<sub>2</sub>) yielded the observation of <sup>4</sup>He at the detection limit of the mass spectrometer (Reference 15). Measured amounts of air were purposely introduced into various N<sub>2</sub> gas samples in order to determine the helium detection limit (see Table 1 of Reference 15). We reported that higher less sensitive detection limits were expected for D<sub>2</sub> + O<sub>2</sub> electrolysis gas samples versus N<sub>2</sub> gas samples because of the different adsorption properties of these gases in the cryofilter (Reference 14). Furthermore, the <sup>4</sup>He content in the chemistry laboratory may have been considerably higher than the normal 5.22 parts per million (ppm) by volume assumed in our calculations (Reference 14). We did not want to overestimate our claims for <sup>4</sup>He production, thus we used the conservative estimate of  $10^{12}$  <sup>4</sup>He atoms per 500 mL as our detection limit. This

detection limit corresponds to about 0.1 parts per billion (ppb). Helium-4 analyses were later performed by a commercial laboratory (Helium Field Operations, Department of the Interior, Amarillo, Texas) that reported a detection limit of 1 to 2 ppb. It is unlikely that the initial helium analyses on our samples at the University of Texas produced a lower detection limit than a commercial laboratory that routinely performs these measurements.

Further evidence for a higher helium-4 detection limit for our measurements is provided by four of our Pyrex flasks that were filled with N<sub>2</sub> from our gas discharge lines and then analyzed for helium at the University of Texas after 9 days of storage (see Table 1 of Reference 15, samples 2 through 5). One flask showed the presence of <sup>4</sup>He at the detection limit, while no helium could be detected for the other three flasks (Reference 15). The diffusion rate of  $3.2 \times 10^{12}$  <sup>4</sup>He atoms/day measured for our N<sub>2</sub>-filled flasks (Reference- 22) and 9 days of storage yields a minimum helium-4 detection limit of  $3 \times 10^{13}$  <sup>4</sup>He atoms/500 mL or 3 ppb for our original experiments (References 22 and 23).

The most solid evidence for our higher helium-4 detection limit was obtained in experiments where the electrolysis gas samples were collected in metal flasks rather than in Pyrex glass flasks. The diffusion of atmospheric helium into the sample flasks was thereby eliminated. For five control experiments yielding no excess power, the mean background helium concentration in our system was  $4.4 \pm 0.6$  ppb or  $5.1 \pm 0.7 \times 10^{13}$  <sup>4</sup>He atoms/500 mL (References 24 and 25). Based on the measured diffusion rate of  $1.9 \times 10^{12}$  <sup>4</sup>He/day for D<sub>2</sub>- and O<sub>2</sub>-filled Pyrex flasks, it would require 27 days before the atmospheric diffusion of helium-4 into our glass flasks would equal the minimum helium detection limit of  $5.1 \times 10^{13}$  <sup>4</sup>He atoms/500 mL. This higher helium-4 detection limit explains why the atmospheric diffusion of helium into our glass flasks was not a major problem in our original studies (References 14 and 15). In order to clearly resolve this detection limit issue, exactly the same procedures and apparatus were used in these experiments, except for the replacement of the glass flasks with the metal flasks.

In retrospect, the higher helium detection limit resolves the issue of atmospheric helium diffusion into our flasks, explains the results for the four N<sub>2</sub>-filled control flasks, and is consistent with the detection limits reported by a commercial laboratory. Furthermore, this higher helium-4 detection limit yields helium production rates of  $10^{11}$  to  $10^{12}$  <sup>4</sup>He/s \* W, which is the correct magnitude for typical deuteron fusion reactions that yield helium as a product (References 22 through 25). The consistent merging of these various results would have been highly improbable if our initial measurements were due to errors, atmospheric contamination, or even deception. Nevertheless, the revision in our helium-4 detection limit was a major issue raised by Jones and Hansen (Reference 11) in their criticism of our work. Our explanations for this change (References 22 through 25) were completely ignored.

Our only gas sample in nine experiments that showed excess power, but no detectable helium, was sample 12/17/90-B (References 14 through 16). Eight days later at the end of this experiment, the D<sub>2</sub>O level in cell B was 5.1 mL lower than in its companion cell A. An unusual voltage increase with time was observed the previous day (12/16/90) for cell B but not for cell A, suggesting that the D<sub>2</sub>O level was already much lower than normal and was not completely covering the electrodes in cell B. We later demonstrated that the low D<sub>2</sub>O level observed in cell B

could yield a false excess heat effect. In early reports (Reference 16), we omitted both cells 12/17/90-A and 12/17/90-B from statistical treatments of our heat-helium results since the two cells were run in series. In later reports (References 14 and 22), we included cell 12/17/90-A in statistical arguments since this cell actually had an acceptable D<sub>2</sub>O level. Naturally, Jones and Hansen (Reference 11) criticized this change. Ironically, it was criticism from Jones for omitting both cells that was voiced during a seminar presented at Brigham Young University (BYU), Provo, Utah, in 1991 that led to this change. The question remains: Do you omit both cells run in series if the experiment is flawed for one cell? If the answer is yes, then you have the earlier result; but if the answer is no, then you have the later result. Unfortunately, the sample 12/17/90 A was inadvertently left out in our preliminary report of correlated excess power and helium production (see Table 2 of Reference 15).

Jones and Hansen (Reference 11) contend that our observation of helium-4 in four out of 10 N<sub>2</sub>-filled flasks must be included for consistent and fair statistical treatment of our data. We totally disagree because air was deliberately introduced into four of these flasks in order to estimate the helium-4 detection limit, and a fifth flask experienced an obvious air leak probably induced by air freight shipment (see Table 1 of Reference 15). The only valid controls were the four flasks filled with boil-off N<sub>2</sub> at our laboratory and then analyzed at the University of Texas 9 days later. As discussed previously, results for these four flasks provide solid evidence that our helium-4 detection limit was considerably higher than 10<sup>12</sup> atoms/500 mL (0.1 ppb) that we claimed initially.

Progress on this topic at our laboratory was very slow in 1991. Many new experiments were conducted, but almost all of them failed to produce any significant excess heat effects. Our two heat-producing palladium cathodes had been cut for helium analyses and were no longer available. Furthermore, a new lot of D<sub>2</sub>O was being used. Late in 1991, two experiments eventually showed a small production of excess power after 6 weeks of electrolysis (Reference 22). Three gas samples were collected in Pyrex flasks as before and sent to Rockwell International Corporation, Canoga Park, California, for analyses. After measuring the rate of atmospheric helium diffusion into these flasks and extrapolating back to zero time, the measured helium-4 contents were 1.34, 1.05, and 0.97 × 10<sup>14</sup> atoms/500 mL for excess power measurements of 0.100, 0.050 and 0.020 W respectively (Reference 22). The error range reported by Rockwell for the helium measurements was ±0.01 × 10<sup>14</sup> atoms/500 mL or ±0.1 ppb. This represents the most accurate helium measurements in any of our experiments. Correcting for our background helium-4 level of 5.1 × 10<sup>13</sup> atoms/ 500 mL yields 2, 2, and 5 × 10<sup>11</sup> <sup>4</sup>He/s \* W (Reference 22). These rates of helium production are in the range of those expected for the fusion of deuterons to form helium-4 (Reference 22). It is interesting to note that Rockwell International, recognized as one of the best laboratories in the world for helium measurements, reports an error range (±1 × 10<sup>12</sup> atoms/500 mL or ±0.1 ppb) identical to our initial (but incorrect) detection limit for helium-4. It is very unlikely that we equaled this accuracy in our initial measurements of helium-4 at the University of Texas in 1990 - 1991 (References 14 through 16).

## CO-DEPOSITION EXPERIMENTS IN 1992

The main objective of the joint program between NAWCWPNS, NCCOSC-NRaD, and NRL that began in January of 1992 was to develop a reliable (reproducible) experimental procedure for the initiation of the anomalous effects associated with the electrochemical loading of metals with deuterium. The initial approach was to explore the co-deposition method reported by Szpak et al. (Reference 26) where palladium metal is deposited from a D<sub>2</sub>O solution containing 0.05 M PdCl<sub>2</sub> and 0.3 M LiCl onto a copper cathode in the presence of evolving deuterium gas. This method reportedly produced excess enthalpy, tritium, and some form of radiation (Reference 26). The deposition of palladium from solution offered the possibility of generating a reproducible cathode material that is simultaneously loaded with deuterium. This approach seemed reasonable considering our poor success rate with solid palladium cathodes during 1991. Furthermore, we had previously conducted a modification of the Szpak co-deposition method that apparently produced excess power and helium-4 (see p. 112 of Reference 14). Another reported advantage for the co-deposition method was that it eliminated large charging times, hence anomalous effects could be detected after about 20 minutes of electrolysis (Reference 26).

Despite the many attractive features of the co-deposition method, our experiments yielded more frustrations. Most experiments failed to produce any excess power that could be detected with our calorimetry, hence no evidence for correlations between heat and helium production could be obtained. Although this method provides for a high-purity palladium deposit that is simultaneously loaded with deuterium, this palladium deposit is often dendritic in nature. Hence, the palladium becomes detached from the electrode, floats in the solution, and adheres to the cell wall above the D<sub>2</sub>O electrolyte level. This finely divided palladium acts as an excellent catalyst for recombination. Our co-deposition experiments sometimes resulted in loud explosions. Another problem was that the dendritic palladium deposit could contact the anode, thus some of the current could pass directly through the cell without producing any electrolysis. Expected changes in the cell voltage were often not detectable due to apparently large resistive effects across the dendritic palladium shorts.

The recombination of the D<sub>2</sub> and O<sub>2</sub> electrolysis gases could always be readily detected in our co-deposition experiments. The extent of this recombination was determined by measuring the current efficiency ( $\gamma$ ) for the D<sub>2</sub>O electrolysis. This was determined by measuring the rate of evolution of the D<sub>2</sub> + O<sub>2</sub> electrolysis gases. The resulting  $\gamma$  can be easily applied to the calorimetric equations (Equations 1 through 3) to correct for any apparent excess enthalpy produced by recombination. This measured current efficiency would also simultaneously correct for any shorting effect or any depolarization effect due to the electrochemical oxidation of D<sub>2</sub> at the anode or reduction of O<sub>2</sub> at the cathode.

A typical co-deposition experiment where significant recombination or dendritic shorting occurs is shown in Figure 6. The apparent excess power, reaching levels up to 18%, could be readily corrected for recombination or other effects by the simultaneous measurement of the rate of evolution of the D<sub>2</sub> + O<sub>2</sub> electrolysis gases used to determine the current efficiency ( $\gamma$ ). The corrected values for X were then close to unity, and the overall ratio of power out/power in was  $X = 1.0005 \pm 0.022$ , i.e., no significant excess power was observed after applying the correction for

the current efficiency. The results in Figure 6 show that recombination can be readily detected and easily corrected in our experiments. These results provide further proof that our calorimetric methods are accurate.

Several other measurements and observations provided secondary checks for any recombination of  $D_2$  and  $O_2$  in our experiments. The volume of  $D_2O$  added to replenish the cell was always recorded to provide another test for any significant recombination effects. Furthermore, the rate of the electrolysis gases passing through the oil bubbler could always be directly observed. Recombination of  $D_2$  and  $O_2$  within the electrolysis cell would slow or even stop the evolution of gases through the bubbler. Occasionally, recombination would even create a partial vacuum within our system, and oil would be drawn up into the upper section of the bubbler tube. Except for these co-deposition experiments involving dendritic palladium deposits, there was never any evidence for recombination in our experiments.

Many experiments have proved that the recombination of  $D_2$  and  $O_2$  electrolysis gases does not occur to any significant level for typical cold fusion studies using solid, fully submerged palladium cathodes (References 7 and 14). Some scientists, however, ignore this evidence and continue to claim that the excess heat effect can be explained by Faradaic efficiencies less than 100% (Reference 12). The recombination effects for nickel (Ni) and Pd cathodes reported by Jones et al. (Reference 12) used current densities of only 1 to  $2\text{mA}/\text{cm}^2$ . Such studies are irrelevant since excess heat effects require a threshold current density of  $100\text{mA}/\text{cm}^2$ . Lowering the current density in water electrolysis experiments will always decrease the current efficiency due to the slower gas evolution that allows the product at one electrode to more readily invade the vicinity and react at the opposing electrode. Furthermore, the current fraction consumed by the electrode reaction of impurities becomes larger at smaller current densities. Contrary to the comments by Jones and Hansen (Reference 11), we always measured the current efficiency at the time of collection of an electrolysis gas sample for helium analysis. This was done volumetrically by measuring the rate of the displacement of water by the electrolysis gases (Reference 14).

Between January and June of 1992, 34 composition experiments were conducted at our laboratory. Apparent excess power was often observed as shown in Figure 6, but measurements of the current efficiency generally showed that the excess power was due to recombination or related effects. Only two of the 34 experiments gave excess power that could not be explained by a lower current efficiency. Figure 7 illustrates one of these experiments showing excess power as high as 12% even after correcting for the current efficiency. The highest excess power in a co-deposition experiment after correcting for the current efficiency was 150 mW.

In retrospect, the volume of the deposited palladium may have been too small for the excess power to be readily measured by our calorimeter. The deposition of all the  $PdCl_2$  would yield only  $0.002\text{ cm}^3$  of palladium, hence a typical excess power density of  $1\text{ W}/\text{cm}^3$  of palladium would produce only 2 mW of excess power. The co-deposition experiments would have to produce  $25\text{ W}/\text{cm}^3$  to yield an excess power of 50 mW that could be measured by our calorimetry. It would be interesting to repeat a co-deposition experiment using a calorimeter that can measure excess power to within  $\pm 1\text{ mW}$ . It is possible that these co-deposition experiments produced excess power in the typical range of  $1\text{ to }5\text{ W}/\text{cm}^3$  of palladium (2 to 10 mW) that was not

detectable with our calorimetry. Szpak et al. (Reference 26) reported an excess enthalpy production between 10 and 40% from crude energy balance determinations.

Our experimental methods in the co-deposition experiments were similar to those reported by Szpak et al. (Reference 26) except for modifications made to accommodate our calorimetry. These changes were discussed with Stan Szpak. Our cathode was a copper rod ( $d = 0.63$  cm,  $\ell = 1.3$  cm) similar in size to our palladium cathodes instead of copper foil ( $A = 4.0$  cm<sup>2</sup>), and we applied constant current rather than constant potential. Typically, we applied a current of 6 mA for the first day and then increased the current to 500 mA or more for the calorimetric measurements. Despite using the same solutions and procedures, the cell voltage displayed versus time on a strip chart recorder often showed variations from one experiment to another. Variations were also observed in the palladium deposits. Some electrodes showed regions of bright, dense palladium deposits rather than the dark dendritic deposits. One experiment even gave a bright palladium deposit on the wall of the glass cell due to some electrodeless deposition process probably involving the deuterium gas. Due to the lack of reproducibility in obtaining excess heat and other anomalous effects, our co-deposition results were never published.

## RADIATION MEASUREMENTS

Radiation monitoring was imposed upon us due to safety concerns but was never intended to be a major focus of our program. Since 1991, we were required to have five radiation dosimeters near our experiments (cells A and B) at distances ranging from 1 to 20 feet away. No significant radiation was measured by these dosimeters. These safety regulations were imposed because of the exposure of dental X-ray films placed near our cells in December 1990 (Reference 14). During this same time period, a GM detector with a thin window (Ludlum model 44-7) positioned near the tops of the cells gave several periods of unexplained high count rates (Reference 14, see also Figure 3 of Reference 22).

This same GM detector later produced only normal count rates for almost a year in various following experiments that failed to produce any significant excess heat effects (see Figure 4 of Reference 22). However, anomalous GM counts were again produced when experiments finally produced measurable excess power in December of 1991 (see Table IV of Reference 22). The count rates returned to normal when these cells were turned off in January of 1992.

A novel feature of the co-deposition experiments was the appearance of anomalous radiation counts shortly after applying current to the electrolysis cells. An example of high radiation counts measured during co-deposition experiments is shown in Figure 8. The same GM detector was used as in previous experiments. Examples of normal counts with this detector are shown in Figure 9. These co-deposition experiments showed high radiation count rates within a few hours of beginning the electrolysis, while the solid palladium rods always required 1 to 2 weeks before anomalous radiation was detected. No anomalous radiation effects were ever observed with this detector when the electrolysis cells were not operating. Plateau determinations for this GM detector with cesium-137 (Cs-137) and iron-55 (Fe-55) sources showed normal behavior (Reference 22). The anomalous radiation was not affected by switching the scalar rate

meter (Ludlum model 2200) to battery power. Moving the GM-detector away from the cell resulted in lower radiation count rates. These results suggest that the radiation was produced by the electrolysis cell rather than by some unknown artifact or error. This anomalous radiation, however, was weak and sporadic in nature. Anomalous radioactive emissions in Pd/D<sub>2</sub>O electrolysis experiments, as measured with GM detectors, were also reported by Uchida et al. (Reference 27). The anomalous emission of low-intensity X-rays during the cathodic polarization of the Pd/D system was recently reported by Szpak et al. (Reference 28) using special cell designs that allowed the positioning of X-ray and  $\gamma$ -ray detectors close to the cathode.

There were also several problems with the anomalous radiation measurements in co-deposition experiments. The major problem is that this effect was never reproducible. On several occasions, Steve King or Gary Phillips, both experts in radiation studies, brought X-ray and germanium detectors from NRL to China Lake to investigate this anomalous radiation. We could never reproduce this effect during these visits. An example of five short experiments during one of their visits is shown in Figure 10. Our GM detector actually showed count rates slightly below normal during these co-deposition studies due to shielding effects of the additional detectors. There was no anomalous radiation.

Another major problem with the anomalous radiation measurements is that most other GM detectors seemed to be blind to this effect. We could seldom obtain substantial high count rates on two GM detectors at the same time. Nevertheless, the construction of GM detectors is an art, and no two detectors behave exactly the same. Every GM detector that we tested had its own unique voltage plateau and sensitivity. We later observed similar anomalous radiation effects with several other types of GM detectors and some correlation of high-count rates between two detectors. An unexpected result was the observation of high-count rates in a co-deposition control experiment in light water (H<sub>2</sub>O).

Problems with the reproducibility of anomalous radiation in the co-deposition experiments are likely due to large changes in the negative logarithm of the hydrogen ion activity (pH) during palladium deposition



The initial 0.025 M PdCl<sub>2</sub> is converted into 0.050 M DCl. The evolution of chlorine gas was observed from the acidic solution. The dissolved chlorine (Cl<sub>2</sub>) can passivate the copper cathode and hinder the palladium deposition. The lingering presence of Cl<sub>2</sub> and O<sub>2</sub> gases in the tubing leading to the oil bubbler in our experiments could have affected following experiments. The turnaround time between experiments was always very short when NRL radiation equipment was in place (see Figure 8). A review of our co-deposition experiments shows that the lingering presence of Cl<sub>2</sub> and O<sub>2</sub> in our tubing likely affected the anomalous radiation in co-deposition experiments. When there were less than 2 days between experiments and no N<sub>2</sub>-flush of the rubber tubing, there was no anomalous radiation in 11 experiments. When there were 3 days or longer between experiments, anomalous radiation was observed in three out of five experiments. Experiments that followed N<sub>2</sub>-flush of our tubing or no prior co-deposition experiments produced

anomalous radiation in five out of eight experiments. This correlation of the anomalous radiation with the experimental conditions suggests that the radiation was real and explains our failure to observe anomalous radiation when visits from NRL were made. The lingering presence of chlorine likely passivated the copper and prevented solid bonding of the palladium to the copper. Poor bonding of the deposited palladium to the substrate could act as a crack and prevent the high deuterium loading required for anomalous effects.

The deposition of palladium directly from D<sub>2</sub>O solutions remains an attractive approach for these experiments. This method offers the advantages of rapid deuterium loading of the palladium with no hydrogen contamination. The proper control of pH and other plating conditions may yield the desired reproducibility of anomalous effects. More sensitive calorimeters should be able to detect the small levels of excess power expected from the amount of palladium present. A major improvement would be the use of deuterated buffers such as deuterated ammonium chloride plus deuterated ammonia (ND<sub>4</sub>Cl + ND<sub>3</sub>) to control the pD (pH) of the solution. Bright palladium deposits rather than dark dendritic deposits would likely yield better results. In a single experiment using the ND<sub>4</sub>Cl + ND<sub>3</sub> buffer solution containing deuterated tetraamine palladous chloride plus lithium chloride (Pd(ND<sub>3</sub>)<sub>4</sub>Cl<sub>2</sub> + LiCl) and a gold (Au)-plated copper cathode, we obtained the anomalous radiation effect as shown in Figure 11.

## TRITIUM MEASUREMENTS

The initial and final tritium concentrations have been measured in nearly every China Lake experiment, but no substantial evidence for tritium production has been obtained. Our first experiments that produced excess heat showed no significant increase in tritium concentrations (Reference 4). An unusual increase in tritium was observed in one experiment following the addition of thiourea. The tritium level in that cell increased from 47 to 84% above that of the stock D<sub>2</sub>O (375 disintegrations per minute per mL (dpm)/mL) within 3 days of the thiourea addition (Reference 22). No thiourea was added to the companion cell, and no unusual increase in the tritium level was observed.

The expected increase in tritium during D<sub>2</sub>O electrolysis is given by

$$\frac{a(t)}{a(o)} = S - (S - 1)e^{-tI / 2FSnV} \quad (7)$$

where a(o) and a(t) are the activity of tritium initially and at the time t, respectively, and S is the isotopic separation factor (Reference 29). This equation assumes a constant current, I, a constant volume, V, and that the number of deuterium atoms far exceeds the number of tritium atoms. At the end of our experiments, due to t being very large (t > 20 days), a(t)/a(o) ~ S. For four experiments using palladium rod cathodes in D<sub>2</sub>O, we obtained a(t)/a(o) values of 1.2, 1.8, 2.0, and 1.4 suggesting S = 1.6 ± 0.4. Equation 7 assumes that S remains constant throughout the course of the experiment. This assumption may not be valid since S depends upon the kinetics of the electrode reactions as well as on the current density (Reference 29). This may explain our variation in S values. The exponential term in Equation 7 can be neglected for electrolysis times larger than about 20 days for our typical experimental conditions (I = 0.5A, V = 18 mL, n = 0.055

mol/mL for D<sub>2</sub>O).

Tritium results for nine co-deposition experiments are given in Table 1. These tritium analysis were performed by P. A. Mosier-Boss at the NRaD laboratory. Five of these experiments produced anomalous excess radiation based on the GM detector results. Theoretical values for a(t)/a(o) calculated from Equation 7 using S = 2 are given in parenthesis for comparisons with the experimental values. Due to the short time periods for co-deposition experiments, the exponential term in Equation 7 cannot be neglected. Only two of these experiments produced a(t)/a(o) values greater than the theoretical calculations (experiments 3/1-3/6/92 and 3/15-3/18/92). Since we have selected a rather high value of S = 2, these two experiments suggest an anomalous production of tritium. This conclusion is especially true for the 3/1-3/6/92 experiment. Nevertheless, the excess tritium production is not large enough to be convincing to most scientists who are skeptical towards this field. Szpak et al. (References 28 and 29) report that tritium is produced sporadically in co-deposition experiments at an estimated rate of about 10<sup>3</sup> to 10<sup>4</sup> atoms per second. This rate of tritium production is about 10<sup>7</sup> to 10<sup>8</sup> below the rate required to produce 100 mW of excess power, assuming deuterium fusion to yield tritium (1 W = 1.55 × 10<sup>12</sup> fusions/s). Our results support the large body of evidence that tritium production in D<sub>2</sub>O electrolysis experiments is far too small to explain any excess heat production (References 7 and 17).

TABLE 1. Tritium Results for Co-Deposition Experiments  
(Cu/D<sub>2</sub>O + LiCl + PdCl<sub>2</sub>/Pt).

Experiment	Excess radiation <sup>a</sup>	a(t)/a <sup>o</sup> <sup>b</sup>	Δ <sup>3</sup> H, dpm/mL	Δ <sup>3</sup> H/day, <sup>c</sup> dpm/mL
4/28-5/4/92	73 σ	1.280 (1.470)	71.29	11.88
3/23-3/31/92	69 σ	1.262 (1.588)	87.74	10.97
2/1-2/13/92	65 σ	1.520 (1.752)	173.68	14.47
3/1-3/6/92	39 σ	1.596 (1.398)	199.79	39.96 <sup>d</sup>
4/1-4/13/92	21 σ	1.282 (1.752)	94.40	7.87
3/9-3/13/92	None	1.205 (1.316)	68.68	17.17
3/15-3/18/92	None	1.205 (1.163)	68.69	22.90
4/24-4/28/92	None	1.200 (1.316)	50.88	12.72
5/14-5/18/92	None	1.183 (1.316)	46.61	11.65

<sup>a</sup> Based on 12-hour counting period using Geiger-Mueller alpha-beta-gamma detector (Ludlum Model 44-7).

<sup>b</sup> Theoretical value in parenthesis is calculated from  $a(t)/a^o = S - (S-1)e^{-t/2FSnV}$  with S = 2.

<sup>c</sup> Omitting highest value (39.96), mean is 11.30 ± 2.72 for experiments with excess radiation and 16.11 ± 5.12 for experiments with no excess radiation.

<sup>d</sup> Value is 10 σ above 11.30 ± 2.72 mean of other experiments with excess radiation.

## NRL MATERIALS: Pd-Ag ALLOY STUDIES

The next approach for this program was to produce palladium and palladium alloy materials within the Navy since the metallurgy of the palladium cathode seemed to be the critical variable. M. Ashraf Imam of NRL prepared and characterized these materials. This approach would remove the major obstacle of depending upon outside suppliers of palladium for good cathode materials that would yield excess heat. Furthermore, we could study factors such as grain size, impurity levels, and alloy compositions that may affect the anomalous excess heat effect. The palladium materials that produced excess heat at China Lake generally had small grain sizes.

Our first experiments with NRL materials involved the study of Pd-silver (Ag) electrodes. These electrodes were stored in our vacuum oven at 130°C for several days prior to use. For these experiments, we did not use silicon rubber or epoxy on any cell component, and we did not connect our cells to the oil bubbler. A platinum lead was attached to these electrodes by NRL using a groove arrangement. No excess power was observed in our calorimetric studies of the Pd-Ag alloys provided by NRL. The calorimetric results for two experiments are shown in Figure 12. The mean X-values are actually slightly below unity for these two studies. This is perhaps due to our neglect of the  $P_{\text{gas}}$  and  $P_{\text{calor}}$  terms (Equations 2 and 3) in our earlier calorimetric studies. At the end of this experiment, a large, deep crack was observed for the cell A cathode. Grooves were made near the top of these Pd-Ag cathodes for the platinum lead attachments that may have also acted as cracks and hindered loading.

Despite the lack of excess heat, an interesting feature of the Pd-Ag studies was the measurement of anomalous radiation with two different detectors. This effect is shown in Figure 13. The same GM detector as used in previous studies was placed near cell A, while a NaI detector was placed near cell B. The NaI detector showed anomalous high count rates after 7 days of electrolysis, while the GM detector showed anomalous radiation after 15 days of electrolysis. The count rates returned to normal for both detectors when these cells were turned off. This is one of our few examples where anomalous radiation was observed in the same set of experiments with two different detectors. Although the detectors were focused on two different cells, they were less than a foot apart and many of the peaks for anomalous radiation seem to occur simultaneously.

It is interesting to compare the long time periods required before the onset of anomalous radiation when solid cathodes are used (Figure 13) with the rapid production of excess radiation in co-deposition experiments (Figures 8 and 11). The palladium is simultaneously loaded with deuterium as it is deposited from solution in the co-deposition studies. This logical difference in behavior between these two types of experiments would not likely be due to erratic radiation detectors. Several other experiments involving solid palladium cathodes produced anomalous radiation, but this effect always required prolonged periods of electrolysis (References 14 and 22). Evidence for radiation that occurred within 12 hours of co-deposition has also been reported by Szpak et al. (Reference 26). In their recent search for emanating radiation using X-ray and y-ray detectors, Szpak et al. (Reference 28) observed an increase in the count rate shortly after the initiation of the Pd/D co-deposition process. Several days of charging were required to observe the same effect on a solid-palladium foil surface (Reference 28). Unfortunately, our sensitive GM detector was accidentally destroyed shortly following the Pd-Ag experiments. Similar

measurements of anomalous radiation were recorded in later experiments using other types of GM detectors. As before, these new detectors never showed anomalous radiation except when the electrolysis experiments were running.

A third experiment using the NRL Pd-Ag alloy also failed to show any significant excess heat effect. This experiment ran for 66 days (27 November 1992 to 4 February 1993) in cell B. The mean ratio of power out to power in was  $X_B = 1.004 \pm 0.013$ . There were no X-values outside the  $\pm 3 \sigma$  effect for this cell. The companion study run in series with the NRL Pd-Ag was a Johnson-Matthey palladium cathode (cell A). This experiment yielded a mean calorimetric value of  $X_A = 1.006 \pm 0.015$ . Once again there was no measurable excess heat in this experiment and no X-value outside the  $\pm 3 \sigma$  effect for this cell. These results support our stated calorimetric error range of approximately  $\pm 1\%$ .

Two NaI radiation detectors were positioned near cells A and B in the above experiment. For the detector near cell A (Pd cathode), the window was set to count only radiation with energies above 660 kiloelectron volts (KeV), while the detector near cell B (Pd-Ag cathode) was set to count all energies. Anomalous radiation was observed with both detectors. The results of this study suggest a broadband radiation effect consisting of energies above and below 660 Key. The larger fraction of the excess radiation detected apparently has energies below 660 Key. Although the anomalous radiation was a  $12 \sigma$  effect for the detector near cell A and a  $19 \sigma$  effect for the detector near cell B, the net increase in radiation was only a 2 to 3% effect (160,336/6 hours versus a normal count of 155,648/6 hours for cell A and 483,427/6 hours versus a normal count of 470,219/6 hours for cell B).

### **NRL MATERIALS: Pd CATHODE STUDIES**

Following the studies of Pd-Ag alloys supplied by NRL that showed no evidence for excess heat, we focused our attention on pure palladium cathodes received from NRL. Six studies of NRL palladium cathodes were completed, but excess heat was observed in only one experiment. This one experiment showing excess power involved a second study of the same cathode. After an experiment that showed no excess enthalpy, the palladium cathode was allowed to de-load for 2 weeks, then the experiment was restarted. On this second study with the same cathode, excess power was observed. This second experiment with the same NRL Pd cathode is shown in Figure 14. The excess power is not large, averaging only about 50 mW, but this effect is persistent throughout most of the experiment. This represents another example where excess power was not observed in the first study but was present in the second study using the same cathode.

Our failure to observe excess heat with NRL-prepared Pd-Ag alloys or Pd cathodes, with the one exception discussed above, was a major disappointment. The reproducible measurement of excess enthalpy with in-house materials would have allowed us to begin to unravel the metallurgical mysteries that contribute to these anomalous effects. Our calorimetric failures, however, were consistent with loading studies performed at both NRL and SRI using these materials. Both laboratories reported poor deuterium loading for the NRL palladium rods.

## OTHER CATHODE MATERIALS: NO EXCESS HEAT

Various other palladium materials were tested in attempts to obtain excess heat and helium-4 measurements. Two new calorimetric cells (C and D) were constructed in June 1992 and placed in operation. These were similar to cells A and B except that foam insulated caps were used to minimize the heat loss through the top of the cells.

Ten consecutive calorimetric studies using cells C and D failed to produce any significant excess enthalpy. Four of these studies, however, were H<sub>2</sub>O-LiOH control calibration experiments. Two experiments using palladium sheet cathodes supplied by Tanaka Kikinzoku Kogyo K. K., Kanagawa, Japan, yielded no excess heat. A. Takahashi et al. (Reference 30) previously reported a very large excess power (100 to 300 W at peaks) for this material. Two repeated experiments using a newly purchased palladium rod from Johnson-Matthey with a cathode size of 4 mm × 1.6 cm did not produce any measurable excess power. Finally, two repeated experiments using Pd-10% Ag (4 mm × 1.6 cm) loaned to us from IMRA Material R and D Co., Ltd. (IMRA), Kariya, Aichi, Japan, failed to produce any excess power. These later experiments, however, are significant in that electrolysis gas samples were collected in metal flasks that helped to determine the background helium levels in our system. This will be discussed in the section, Heat and Helium Studies Using Metal Flasks.

Numerous experiments conducted in calorimetric cells A and B involving various cathode materials also failed to produce any significant excess enthalpy. Two experiments used palladium plated cathodes (Pd/Au/Cu) where gold is first plated onto a copper rod then palladium is plated onto the gold. No excess heat was observed. The Johnson-Matthey palladium rod run in cell A as a companion cell to the third NRL Pd-Ag cathode failed to produce any excess heat.

A novel experiment using cells A and B involved acidified D<sub>2</sub>O prepared by adding 10.6 mL of concentrated sulfuric acid (H<sub>2</sub>SO<sub>4</sub>) to 60 mL of D<sub>2</sub>O. Cold-rolled palladium sheet cathodes and procedures were supplied by Professor John Dash of Portland State University who claimed a reproducible excess heat effect with his method. No calorimetric evidence for excess heat could be established for either cell in our experiments. The power ratio for cell B is shown in Figure 2. The input and output powers for cell B are illustrated in Figure 15. The calorimetrically- measured output power tracks very closely to the electrochemical input power. This verifies our calorimetric accuracy over a range of input powers. The measured excess power for this cell is shown in Figure 16. All results are within  $\pm 2 \sigma$  ( $\pm 40$  mW) of our estimated calorimetric error ( $\pm 20$  mW). These experiments provide a test of our calorimetry in a completely different solution (D<sub>2</sub>O + H<sub>2</sub>SO<sub>4</sub>). A notable feature of these experiments was the smaller voltage drop across the cells due to the high conductivity of this solution. The noise or oscillations in the cell voltages was also extremely small in these experiments. Nevertheless, no excess heat was measured. Anomalous radiation, however, was observed in these experiments with the use of a new type of GM detector purchased from TGM Detectors, Inc. (TGM), Waltham, Massachusetts. These detectors consisted of high-sensitivity platinum and tungsten-lined GM tubes.

## OTHER CATHODE MATERIALS PRODUCING EXCESS HEAT

Despite the many failures, several new experiments produced measurable amounts of excess enthalpy. The most notable examples involved cathode materials loaned to us by Martin Fleischmann of IMRA Europe, Valbonne, France. Two experiments involving palladium rods of different diameters (1 and 2 mm) were set up in cells C and D. Measurable amounts of excess heat were observed for both cells, and the larger diameter rod produced the larger amount of excess power. The excess power results for the 2-mm Pd rod are shown in Figure 17. This experiment began on 23 April 1993 with the current held at 50 mA until 1 May 1993. No significant excess power was observed until 7 May 1993. The average excess power was about 50 mW until 20 June 1993. Excess power peaks as large as 250 mW were observed later in this experiment. The cell voltage became very high (21 V) near the end of this experiment, producing high-cell temperatures (88 C) and less accurate calorimetry. The decline in excess power early in July may simply be due to operating outside the calibration range for this calorimeter. A smaller excess power effect was observed for the 1-mm-diameter palladium used in cell C. A following experiment in H<sub>2</sub>O-LiOH in cell C using the same 1-mm-palladium cathode did not produce any significant excess power. Electrolysis gas samples were collected in metal flasks for helium analysis for each of these experiments, and results will be discussed in a later section.

Another sample provided to us by Martin Fleischmann was a Pd-Ce alloy material. This experiment began on 15 February 1994, and the onset of excess power production was observed on 4 March 1994. The excess power versus time for the Pd-Ce cathode is displayed in Figure 18. The excess power levels for this cell reached values as high as 350 mW. The excess power production for Pd-Ce in cell C remained for over 100 days of electrolysis. Gas samples were again collected in metal flasks for helium analysis. A repeated run with the Pd-Ce cathode in cell C again showed excess power levels up to 150 mW.

Several other experiments produced small excess power effects. A palladium-plated copper cathode (Pd/Cu) used in a D<sub>2</sub>O-LiOD solution containing 500 ppm boron oxide (B<sub>2</sub>O<sub>3</sub>) produced a steady 2 to 4% excess power in cell D. A companion cell in series using a similar Pd/Cu cathode in D<sub>2</sub>O-LiOD containing 500 ppm sodium metasilicate (Na<sub>2</sub>SiO<sub>3</sub> · 9 H<sub>2</sub>O) failed to produce any measurable excess power. An interesting observation at the end of these experiments was the dark material on the Pd/Cu used with Na<sub>2</sub>SiO<sub>3</sub> · 9 H<sub>2</sub>O and the bright appearance of Pd/Cu used with B<sub>2</sub>O<sub>3</sub>. The Pd/Cu cathode in D<sub>2</sub>O-LiOD plus 500 ppm B<sub>2</sub>O<sub>3</sub> is our only experiment involving a palladium-plated cathode that produced excess power. Although this 2 to 4% excess power is not clearly outside the bounds of calorimetric error, it suggests a possible role for boron in the anomalous excess heat effect. Glass contains B<sub>2</sub>O<sub>3</sub> and boron is generally found as an impurity in palladium.

Experiments that began on 26 February 1993 using the Tanaka palladium plate from Japan in cell A and Johnson-Matthey 1-mm-diameter palladium wire in cell B produced small levels of excess power. The excess power was only 50-100 mW for these two cells or 3 to 4% above the input power. Nevertheless, larger effects would not be expected based on the small volume of these cathodes (0.05 cm<sup>3</sup> for the palladium plate and 0.02 cm<sup>3</sup> for the palladium wire). The excess power densities were in the normal range of 1 to 5 W/cm<sup>3</sup> for these two cathodes. The small

excess power was fairly steady during these experiments, but effects this small are not clearly outside the limit of our calorimetric error. This Johnson-Matthey wire became a focus of later experiments since we had a large supply of this palladium. Experiments by Wilford Hansen at Utah State University, Logan, Utah, reported excess power using this palladium wire as did experiments at China Lake using our more sensitive calorimeters developed by Kendall Johnson.

## USE OF ADDITIVES

The addition of substances that poison the cathode and increase the overvoltage has been advocated since the first report of cold fusion studies on 23 March 1989. McKubre et al. (Reference 1) have tested aluminum (Al), boron (B), Cu, Ni, silicon (Si), beryllium (Be), and classical hydrogen recombination poisons as additives in their experiments. The presence of Al or Si is believed to be important in promoting deuterium loading and excess heat. For experiments performed in quartz or glass vessels, silicon will be present in increasing amounts as this element dissolves in the LiOD solution.

We have investigated various additives in many different experiments, but no significant excess heat events can be clearly traced to these additives. The additives investigated at China Lake include sulfur, zinc oxide (ZnO), thiourea, silicates, Al, B, and magnesium perchlorate ( $Mg(ClO_4)_2$ ). One of our early publications (Reference 4) reports on additions of sulfur and ZnO to the solutions in two different cells, but no measurable changes could be discerned in the excess power production. As mentioned previously, a small excess heat effect (2 to 4%) was measured using a Pd/Cu cathode in  $D_2O$ -LiOD containing 500 ppm  $B_2O_3$ . The addition of silicates often produced severe passivation of the electrodes, resulting in high-cell voltages, but no significant excess power was detected. The addition of  $Mg(ClO_4)_2$  produced a sharp decrease in cell voltages due to an apparent depassivating effect on the electrodes. In several experiments, the addition of  $Mg(ClO_4)_2$  seemed to produce a small increase in excess power. Perhaps our cathodes were usually covered by silicates from the glass cells, hence other additives produced only small effects. As reported previously (Reference 22), the addition of thiourea to one of our cells may have increased the tritium production.

## HEAT AND HELIUM STUDIES USING METAL FLASKS

Metal flasks were used in place of glass flasks to collect electrolysis gas samples for helium analysis in a new set of heat and helium experiments. The use of metal flasks prevents the diffusion of atmospheric helium into the flasks after they are sealed. The valves used in these flasks were modified to effect a metal seal with a nickel gasket. Experimental details for these metal flasks are reported elsewhere (Reference 30). All other components of the cells, gas lines, and oil bubblers remained the same in order to relate these new measurements to previous measurements using glass flasks. The rubber tubing used for the gas lines was periodically replaced to maintain the same conditions as in previous studies.

Six control experiments using four metal flasks where no excess power was measured

yielded  $4.5 \pm 0.5$  ppb  $^4\text{He}$  or  $5.1 \pm 0.6 \times 10^{13}$   $^4\text{He}$  atoms/500 mL as shown in Table 2. These values show that our experimental procedures are very consistent. Five of these control experiments were reported elsewhere (References 24, 25, and 30). The helium analysis was performed by the U.S. Bureau of Mines laboratory in Amarillo, Texas, and yielded a typical error range of  $\pm 1.1$  ppb. These samples were all from experiments that never produced any evidence for excess heat. No measurable differences occurred in our background levels of  $^4\text{He}$  over a period of more than a year. Four metal flasks were employed, but the particular metal flask that was used produced no significant difference in the background helium result (Reference 25).

TABLE 2. Helium Measurements in Control Experiments Using Metal Flasks.  
No excess power was measured.

Electrode	Flask/cell, date	$^4\text{He}^a$ , ppb	$^4\text{He}$ , atoms/ 500 mL
Pd Rod <sup>b</sup> (4 mm × 1.6 cm)	1/C (2/24/93)	$4.8 \pm 1.1$	$5.5 \times 10^{13}$
Pd-Ag Rod <sup>b</sup> (4 mm × 1.6 cm)	2/D (2/24/93)	$4.6 \pm 1.1$	$5.2 \times 10^{13}$
Pd Rod <sup>b</sup> (4 mm × 1.6 cm)	3/C (2/28/93)	$4.9 \pm 1.1$	$5.6 \times 10^{13}$
Pd-Ag Rod <sup>b</sup> (4 mm × 1.6 cm)	4/D (2/28/93)	$3.4 \pm 1.1$	$3.9 \times 10^{13}$
PdRod <sup>c</sup> (1mm × 1.5cm)	3/C (7/7/93)	$4.5 \pm 1.5$	$5.1 \times 10^{13}$
Pd Rod <sup>d</sup> (4.1 mm × 1.9 cm)	3/D (3/30/94)	$4.6 \pm 1.4$	$5.2 \times 10^{13}$
(Mean)		$4.5 \pm 0.5$	$(5.1 \pm 0.6 \times 10^{13})$

<sup>a</sup> Helium analysis by U.S. Bureau of Mines, Amarillo, Texas.

<sup>b</sup> D<sub>2</sub>O + LiOD (I = 500 mA).

<sup>c</sup> H<sub>2</sub>O + LiOH (I = 500 mA).

<sup>d</sup> D<sub>2</sub>O + LiOD (I = 600 mA).

In experiments producing excess power, seven helium measurements using these same four metal flasks were completed. Results for five of these studies have been reported previously (References 24, 25, and 30). Results for all seven experiments are given in Table 3. After correcting for the background level of helium measured in our control studies, each experiment in Table 3 yields a helium-4 production rate close to  $1 \times 10^{11}$   $^4\text{He/s W}$ . These results using metal flasks are consistent with our previous results using glass flasks (References 14 and 22).

We completed 18 measurements of excess helium for experiments producing excess heat. These helium measurements were performed at three different laboratories: the University of Texas (References 14 and 15), Rockwell International (Reference 22), and the U.S. Bureau of Mines (References 24, 25, and 31). The helium measurements from all three laboratories yield helium-4 production rates of 1011 to 1012  $^4\text{He/s} * \text{W}$  (Reference 25). We have also completed 12 measurements of helium for experiments that did not produce any measurable excess heat, including six experiments in H<sub>2</sub>O-LiOH solutions. These experiments all yielded either undetectable amounts of helium (References 14 through 16) or lower levels of helium-4 (References 24, 25, and 31) that established the background helium level present in our system, as well as the minimum helium-4 detection limit for our first experiments using glass flasks. This background level of helium-4 arises mainly from the diffusion of atmospheric helium through the thick-walled rubber tubing used in our gas lines (Reference 25).

TABLE 3. Helium Measurements Using Metal Flasks.  
Experiments producing excess power.

Electrode	Flask/cell, date	<sup>4</sup> He <sup>a</sup> , ppb	Px,W	<sup>4</sup> He/s *W <sup>b</sup>
Pd Sheet (1.0 mm × 3.2 cm × 1.6 cm)	3/A (5/21/93)	9.0 ±1.1	0.055	1.6 × 10 <sup>11</sup>
Pd Rod <sup>c</sup> ( 1 mm × 2.0 cm)	4/B (5/21/93)	9.7 ±1.1	0.040	2.5 × 10 <sup>11</sup>
Pd Rod <sup>c</sup> (1 mm × 1.5 cm)	1/C (5/30/93)	7.4 ±1.1	0.040	1.4 × 10 <sup>11</sup>
Pd Rod <sup>c</sup> (2 mm × 1.2 cm)	2/D (5/30/93)	6.7 ±1.1	0.060	7.0 × 10 <sup>10</sup>
Pd Rod <sup>d</sup> (4 mm × 2.3 cm)	1/A (7/7/93)	5.4 ±1.5	0.030	7.5 × 10 <sup>10</sup>
Pd Rod <sup>d</sup> (6.35 mm × 2.1 cm)	2/A (9/13/94)	7.9 ±1.7	0.070	1.2 × 10 <sup>11</sup>
Pd-B Rod <sup>d</sup> (6 mm × 2.0 cm)	3/B (9/13/94)	9.4 ±1.8	0.120	1.0 × 10 <sup>11</sup>

<sup>a</sup> Helium analysis by U.S. Bureau of Mines, Amarillo, Texas.

<sup>b</sup> Corrected for background helium level of  $5.1 \times 10^{13}$  <sup>4</sup>He/500 mL.

<sup>c</sup> D<sub>2</sub>O + LiOD (I = 400 mA).

<sup>d</sup> D<sub>2</sub>O + LiOD (I = 500 mA).

The helium measurements presented in Table 3 are all taken from experiments that produced steady excess heat effects. For example, the 2/D (5/30/93) sample is from the experiments involving the 2-mm palladium rod obtained from Martin Fleischmann that is shown in Figure 17. Larger excess power effects were present later in this experiment, but no metal flasks were available due to the slow turnaround time for the shipment and analysis. The 1/C (5/30/93) sample involves the 1-mm palladium rod, while the 3/A (5/12/93) result was obtained with the Tanaka palladium sheet cathode. The largest excess power in Table 3 was obtained using a Pd-B cathode (0.75 weight %B) prepared by NRL. The excess power measurements for this Pd-B experiment are presented in Figure 19.

Higher excess power effects would have been better for the helium measurements using metal flasks (Table 3). Although the excess power effects are small, these measurements involved experiments where a consistent excess power was observed. In contrast, experiments used for control studies never showed any significant evidence for excess power (References 24, 25, and 31). A theoretical relationship between excess power and helium production is given in Table 4. Excess power levels of 200 mW or higher would be desirable to minimize the errors in the calorimetry and helium measurements. It should be noted that for any given excess power, the helium concentration in the electrolysis gas stream will be inversely proportional to the current (Reference 25).

TABLE 4. Theoretical Relationship Between Excess Power and Helium Production. Magnitude of experimental errors.

Px, W	<sup>4</sup> He <sup>a</sup> , ppb	<sup>4</sup> He, atoms/ 500 mL	<sup>4</sup> He error, <sup>b</sup> %	Calorimetric error, <sup>c</sup> %
0.050	5.6	$6.38 \times 10^{13}$	18	40
0.100	11.2	$1.28 \times 10^{14}$	8.9	20
0.200	22.4	$2.55 \times 10^{14}$	4.5	10
0.500	56.0	$6.38 \times 10^{14}$	1.8	4
1.000	112.0	$1.28 \times 10^{15}$	0.9	2

<sup>a</sup> For I = 500 mA assuming  ${}^2\text{D} + {}^2\text{D} \rightarrow {}^4\text{He} + 23.8 \text{ MeV}$  is the fusion reaction.

<sup>b</sup>  $\pm 1$  ppb.

<sup>c</sup>  $\pm 0.020$  W.

NOTE: N. Lewis (CalTech) and D. Albagli (MIT) reported gas-phase helium detection limits of 1000 ppb (1 ppm) in their 1989-1990 publications.

A puzzling helium result was obtained for the Pd-Ce cathode that produced the large excess power effect shown in Figure 18. Despite excess power measurements as large as 300 mW, no excess helium could be detected. These results are presented in Table 5. The companion cell employing a NRL Pd rod gave no excess power and almost the same amount of helium-4 ( $4.6 \pm 1.4$  ppb) as found for the Pd-Ce experiment. This represents our only experiment where valid excess power was measured but no excess helium was detected. An experiment at SRI using the same source for Pd-Ce also gave excess heat but no excess helium according to Ben Bush. An earlier experiment using a palladium cathode (sample 12/17/90-B) yielded 11% excess power (290 mW) but no detectable helium (Reference 14 and 22). This 1990 experiment, however, was flawed due to a very low D<sub>2</sub>O level in the cell (Reference 14 and 22). Later experiments showed that this low D<sub>2</sub>O level could produce a calorimetric error that would account for most of the reported excess power. There were no other palladium cathodes that did not show a correlation between excess power and helium production.

We can estimate from Figure 18 that the Pd-Ce cathode produced 1.1 megajoules (MJ) of excess heat over a 110-day period. No chemical process can account for more than about 20 kJ in our system (Reference 4). Assuming typical deuteron fusion reactions that produce helium-4, the 1.1 MJ of excess enthalpy would produce a minimum of  $3.7 \times 10^{17}$  atoms of helium-4 (Reference 22). Since no measurable helium was observed in the gas phase (Table 5), these helium atoms may remain in the Pd-Ce electrode. This would correspond to  $1.4 \times 10^{14}$  atoms/milligram (mg) and would be readily measurable by Rockwell International ( $10^8$  atoms/mg detection limit, see Reference 14). The measurement of <sup>4</sup>He atoms within the Pd-Ce cathode has not been done. One

problem is our lack of an unused Pd-Ce sample that could be tested as a control.

TABLE 5. Excess Power and Helium Measurements in Experiments Using a Palladium-Cerium Cathode.

Electrode	Flask/cell, date	$^4\text{He}^a$ , ppb	Px, W	$^4\text{He/s} * W^b$
Pd-Ce Rod <sup>c</sup> (4.1 mm × 1.9cm)	1C (3/30/94)	4.6 ±1.4	0.17	0
Pd-Ce Rod <sup>c</sup> (4.1 mm × 1.9cm)	4/C (4/19/94)	4.7 ±1.3	0.30	0
NRL Pd Rod <sup>c</sup> (4.1 mm × 1.9 cm)	3/D (3/30/94)	4.6 ±1.4	0	...
NRL Pd Rod <sup>c</sup> (4.1 mm × 1.9 cm)	2/D (4/19/94)	>1000 <sup>d</sup>	0	...

<sup>a</sup> Metal collection flasks, analysis by U.S. Bureau of Mines, Amarillo, Texas.

<sup>b</sup> Corrected for background helium level of 4.5 ±0.5 ppb.

<sup>c</sup> D<sub>2</sub>O + LiOD (I = 600 mA).

<sup>d</sup> Broken solder joint on metal flask.

### MISCELLANEOUS HELIUM MEASUREMENTS

Four metal flasks were received from NRL to test for helium measurements. These were connected to the Pd-Ce experiment (cell C) and the NRL Pd experiment (cell D). Unusually high-helium concentrations were obtained, i.e., 41.5 ±5.6 ppb for the Pd-Ce sample and 40.6 ±4.3 ppb for the NRL Pd sample (I = 600 mA). Later experiments using the other two NRL flasks yielded 5.6 ±1.6 ppb for the Pd-Ce study (cell C) and 5.4 ±1.6ppb for the NRL Pd study (cell D) with I = 800 mA. The large differences in helium amounts for these two sets of experiments using four different metal flasks cannot be readily explained. Perhaps the fact that the valves for the NRL flasks were not modified to give a metal-to-metal seal is a factor. Nevertheless, the helium measurements for the Pd-Ce and NRL Pd cells were always in close agreement, as found in Table 5, using our metal flasks. The second Pd-Ce helium measurements (5.6 ±1.6 ppb) involved a near boil-off condition (T = 94°C) due to a high-cell voltage produced by passivation, yet the measured helium concentration remained small.

Glass flasks were used in four helium measurements involving the 1- and 2-mm palladium rods obtained from Martin Fleischmann that produced excess heat (see Figure 17). The metal flasks normally used had been shipped out for earlier helium measurements and were unavailable. Flask # 2 (6/16/93) for cell D (2-mm Pd) gave 15.2 ±2.3 ppb for I = 400 mA and 120 mW of excess power while flask # 1 (6/29/93) for this same cell gave 8.9 ±1.8 ppb for I = 600 mA and 135 mW of excess power. Correcting for the background helium and the rate of helium diffusion into the glass flasks yields  $1 \times 10^{11}$   $^4\text{He/s} * W$  for flask # 2 and  $4 \times 10^{10}$   $^4\text{He/s} * W$  for flask # 1. These results are somewhat low, especially for flask # 1, but still are reasonably consistent with

those obtained using metal flasks (Table 3). The other two glass flasks were used with cell C (1-mm Pd) under conditions of high-cell temperatures where our calorimetry is not as accurate. Flask # 5 (6/17/93) for cell C gave  $14.0 \pm 2.2$  ppb helium under boil-off conditions with severe electrode polarization ( $E = 23$  V,  $I = 450$  mA). Flask # 20 (6/20/93) for cell C yielded  $16.9 \pm 2.4$  ppb helium at a cell temperature of about  $85^\circ\text{C}$ . Judging from these helium results, no substantial excess of helium-4 was produced during cell boil-off conditions. Furthermore, there did not appear to be any measurable excess power effects at these high-cell temperatures.

Glass flasks were used with a  $\text{D}_2\text{O-LiCl}$  study (cell A) and  $\text{H}_2\text{O-LiCl}$  experiment (cell B). Electrolysis gas samples taken on 13 September 1991 yielded  $14 \pm 2$  ppb helium for cell A and  $17 \pm 2$  ppb helium for cell B ( $I = 525$  mA). No significant excess power was measured in either experiment. The background helium levels were rather high in these two experiments. These two studies differ from other experiments in that they involved a modification of the co-deposition process via anodic and cathodic treatments of the palladium with 0.3 M LiCl replacing the usual LiOD electrolyte.

### **NRL PALLADIUM-BORON MATERIALS**

The most successful collaboration in this program was the production of Pd-B alloys at NRL and the calorimetric testing of these materials at China Lake. Seven out of eight palladium-boron experiments produced evidence for excess heat production. These calorimetric studies of Pd-B materials were all completed during the final year of this program (1994-1995). As mentioned previously, the largest excess power reported in Table 3 for helium measurements using metal flasks was obtained using a Pd-B cathode prepared by NRL. The excess power measurements for this experiment are shown in Figure 19. This cathode contained 0.75 weight % B and had a 6-mm diameter and a 2.0 cm length with rounded ends. This Pd-B experiment was turned off and then re-started 8 days later. Excess power was again observed as shown in Figure 20. The excess power levels were similar to the first experiment (Figure 19) except for higher power peaks later in the second experiment (Figure 20). This again demonstrates that excess power can be obtained in repeated experiments using the same cathode.

The next two studies of NRL Pd-B alloys showed excess power in one experiment, but no significant effect in the other experiment. These measurements are shown in Figures 21 and 22. The excess power for cell C showed a gradual increase with time and reached levels exceeding 300 mW (Figure 21). The second cell run in series (cell D) showed fluctuations mainly within  $\pm 50$  mW and no significant production of excess power (Figure 22). There was clearly no gradual increase of excess power as shown in Figure 21. It was noted at the beginning of this experiment that the cathode in cell D was poorly aligned. This leads to an uneven current distribution and low loading of deuterium into the cathode. After this experiment, examination of the Pd-B cathode that did not produce excess power (cell D) showed an obvious flaw. Swaging of this rod had produced a large, folded-over metal region that would act as a long crack. In contrast, the heat-producing Pd-B cathode had no obvious flaws or cracks. Both cathodes consisted of 0.75 weight % B, with a rod diameter of 2.5 mm and a length of 2.5 cm ( $V = 0.12 \text{ cm}^3$ ). The end of the heat-producing electrode was left straight, while the end of the other cathode was rounded using a

file. No silicon rubber or epoxy was used in these two experiments, in contrast to the experiments shown in Figures 19 and 20. No helium measurements were performed for these experiments or for any later experiments, because we were directed to focus only on the excess-heat effect during the last year of this program.

The next series of Pd-B alloy studies explored the effect of lower B concentrations. Two studies of the 0.5 weight % B alloy are shown in Figures 23 and 24. These experiments began on 3 March 1995, thus the first data points shown are after 11 days of electrolysis. A fairly steady excess-power effect is found in both experiments with typical levels of 50 to 100 mW. Results for the 0.25 weight % B alloys are shown in Figure 25 and 26. The excess power averages about 100 mW for cell C (Figure 25) with peaks of 150 to 200 mW. In contrast, cell D (Figure 26) shows a 5-day period of excess power early in the experiment and then no other episodes of significant excess power. The power ratios for cells C and D are shown in Figures 27 and 28, respectively. Large, negative deviations in excess power were usually associated with electrode passivation problems that produced high-cell temperatures outside our normal calibration range. The addition of  $\text{Mg}(\text{ClO}_4)_2$  to break down the passivation or the increase of the LiOD concentration brought the cell temperature back to the normal range. Although the largest excess power was observed with the higher B concentrations (Figure 21), there is no clear picture of how the B content in the palladium affects the excess power. Flaws, cracks, or other defects in the Pd-B alloys likely play a major role, as shown by the results in Figures 21 and 22. The 0.5 and 0.25 weight % B alloys all had dimensions of 4 mm  $\times$  2 cm ( $V = 0.25 \text{ cm}^3$ ). Microscopic examinations of these four Pd-B cathodes following the experiments did not reveal any significant cracks, folded-over metal regions, or other flaws for these NRL materials. The high-success rate for excess-power production for Pd-B alloys suggests that this would be a fruitful area for further research. Perhaps the presence of B initially as an impurity in the palladium or the incorporation of B from the glass into the palladium during the experiment is a factor in the reproducibility problem for excess-heat production. It is also possible that the increased hardness of the palladium due to the added B allows it to better withstand the high stresses induced by the experiments.

Deuterium loading studies by the weighing method were conducted for six of the Pd-B alloy experiments. In general, the rate of loading of deuterium into the alloy was much slower than the rate observed for pure palladium electrodes. Studies of loading at NRL using resistance measurements also showed very slow loading rates for Pd-B alloys. The presence of B at the grain boundaries likely hinders the ingress and egress of deuterium.

TABLE 6. Loading Studies by the Weighing Method Following 5 Days and 10 Days of Electrolysis.

Electrode	Xo, 5 days <sup>a</sup>	Xo, 10 days <sup>b</sup>
Cell A Pd-0.5% B (#94081701)	0.643	0.640
Cell B Pd-0.5% B (#94081702)	0.604	0.652
Cell C Pd-0.25% B (#94081801)	0.692	0.716
Cell D Pd-0.25% B (#94081802)	0.647	0.695

<sup>a</sup> I = 50 mA for 5 days.

<sup>b</sup> I = 100 mA for the second 5-day period. NOTE: Microscopic examinations showed surface nicks and scratches but no major flaws on electrodes.

Table 6 presents loading studies by the weighing method for the 0.50 and 0.25 weight % B alloys. The loading of deuterium into the Pd-B alloys is slow and the loading levels are not especially high. Table 7 presents de-loading studies for these same four Pd-B alloys. The rate of deuterium exiting the electrode is very slow, hence the weighing method works quite well for these alloys. A comparison of Tables 6 and 7 indicates that the deuterium loading levels did not increase significantly after the first 10 days of electrolysis for any of these Pd-B alloy cathodes. The alloys with the lower concentration of B (0.25 weight %, cells C and D) always showed somewhat higher loading levels than the 0.50 weight % alloys (cells A and B). McKubre et al. (Reference 10) has shown a clear relationship between excess power and loading levels for pure palladium cathodes.

TABLE 7. De-loading Studies by the Weighing Method.

Time, hours	Pd-0.5% B, Cell A	Pd-0.5% B, Cell B	PPd-0.25% B, Cell C	Pd-0.25% B, Cell D
0	0.617	0.643	0.687	0.687
12	0.490	0.497	0.518	0.512
36	0.350	0.368	0.446	0.367
67	0.228	0.261	0.215	0.190
112	0.152	0.161	0.108	0.069
181	0.100	0.051	0.034	0.010
282	0.065	0.003	0.010	0.003

Loading studies for two Pd-B alloys containing 0.75 weight % B are shown in Table 8. Excess power was produced for cell C but not for cell D (see Figures 21 and 22). The deuterium loading level was always higher for the heat-producing alloy. A large difference in deuterium loading was obtained at the end of these experiments (0.85 versus 0.63). As mentioned previously, the cathode in cell D had a flaw that likely limited the loading. This flaw was a large folded-over metal region produced by the swaying process at NRL. The de-loading of deuterium was very slow for both alloys, and required 17 days before a constant weight was observed. The final loading levels in Table 8 (0.85 and 0.63) are corrected for weight gains of the cathodes during electrolysis due to deposits of silicon and other impurities. It is interesting to note that the gradual increase in loading for cell C is consistent with the gradual increase in excess power for this experiment (Figure 21). The lack of excess power for cell D (Figure 22) is also consistent with its lower loading level (Table 8), the poor alignment of this cathode, and the detection of a major flaw in this electrode. Calorimetric errors would not likely lead to this solid agreement with other measurements and observations. In summary, this Pd-B alloy collaboration between China Lake and NRL produced one of our best heat and helium correlations (Table 3), a high success rate for excess power production (Figures 19 through 26), and some interesting loading studies (Tables 6 through 8). These Pd-B results could be a key to the reproducibility problem that has hindered progress for this field of research. The Pd-B rods, however, should be carefully examined prior to any experiments for flaws produced by any swaying operations on these very hard materials.

TABLE 8. Loading Studies by the Weighing Method.

Time, days	Pd-0.75% B, Cell C	Pd-0.75% B, Cell D
7	0.580	0.550
12	0.614	0.594
100	0.85	0.63

### PALLADIUM WIRE STUDIES

One Johnson-Matthey sample (1-mm wire) had previously given both excess-heat and helium production at China Lake (see Table 3, cell B). There was an ample supply of this wire, hence experiments were planned for China Lake, NRL, the University of Utah, and Utah State University using this material. The same source of D<sub>2</sub>O and lithium were to be used at each laboratory along with the same experimental procedures. The Pd-B alloy studies (Figures 23 through 28) and the palladium wire studies (Figures 29 through 35) represent the completion of all experiments outlined for our laboratory by our sponsor at our final planning session in January 1995.

Four experiments using this palladium wire with our standard calorimeters (cells A, B, C,

and D) were completed at China Lake as the final segment of our program. Excess power was obtained in one of these experiments. The calorimetric measurements for cells A, B, C, and D are shown in Figures 29 through 32, respectively. The excess-power effect was observed for cell C and peaked at about 300 mW or 10% above the input power. There was a consistent excess power effect for this cell (cell C) over most of the experiment. The power ratio for cell C is displayed in Figure 33. Turning the cell off for 3 days and then back on showed normal behavior, hence the excess power was not due to any calibration changes in the cell. A second calibration check for each cell was performed about 2 weeks later, as shown in Figures 29 through 33. The companion cell in the series (cell D) showed no consistent evidence for excess-power production. Similar experiments in cells A and B (Figures 29 and 30) produced no evidence for excess power that was clearly outside the range of experimental errors. The palladium cathodes in cells A and B were 2.5 cm in length ( $A = 0.40 \text{ cm}^2$ ,  $V = 0.020 \text{ cm}^3$ ), while the cathode in cells C and D were 2.0 cm in length ( $A = 0.32 \text{ cm}^2$ ,  $V = 0.016 \text{ cm}^3$ ). For the experiment in cell C, a rather large excess-power density of  $15 \text{ W/cm}^3$  was observed. These four experiments were all hindered by unusually large fluctuations in the cell voltages ( $\pm 0.5 \text{ V}$ ) that were traced to a foaming problem in the  $\text{D}_2\text{O-LiOD}$  solutions. This foam would collect in the coils of the anode and then release. These four experiments all used  $\text{D}_2\text{O}$  supplied by NRL (Cambridge Isotope Laboratories, Lot No. PSO EH-283) and lithium foil supplied also by NRL (Alfa/Aesar Stock No. 10769). This shows that the  $\text{D}_2\text{O}$  can be an important uncontrolled variable in these experiments. The experimental protocol used in these experiments was to run at  $100 \text{ mA/cm}^2$  for a day and then at  $200 \text{ mA/cm}^2$  for 10 days. The normal operating current was 400 to 600 mA ( $1000$  to  $1500 \text{ mA/cm}^2$ ). The higher current density used for these small cathodes is consistent with the higher power density ( $15 \text{ W/cm}^3$ ) obtained (Reference 5).

The improved China Lake calorimetry, shown in Figure 4 and discussed on page 10 in this report, was used in two studies of the 1-mm Johnson-Matthey wire ( $1 \text{ mm} \times 4.3 \text{ cm}$ ). One experiment showed several episodes of small excess power, while the other experiment showed only normal behavior. Two separate episodes of small excess power are shown in Figures 34 and 35. The onset of excess power in Figure 34 is sudden, and there is no clear trigger for this event. However, LiOD was added to the other cell in the series at about this same time. The loss of the excess-power effect in Figure 34 was also sudden, but this effect correlated to the addition of LiOD to both cells at 844 hours. This produced a decrease for the input power to the cell, hence a decrease in cell temperature. The excess power of 70 mW shown in Figure 34 corresponds to 2 W per  $\text{cm}^3$  of palladium. This is close to the excess power expected for a current density of  $259 \text{ mA/cm}^2$  (References 5 and 6). Figure 35 shows a fluctuating excess power excursion later in this same experiment. McKubre et al. (Reference 1) also report fluctuations in excess power that appear to be correlated with oscillations of the cathode loading. The onset of the excess power in Figure 35 occurred shortly after a reduction in the heater power. The resulting change in the cell temperature may have triggered this excess-power event. The abrupt end to the excess-power fluctuations is not related to any known events. The results in Figures 34 and 35 show how this more sensitive calorimetry can be used to study events that may trigger or kill the excess-power effect. These types of studies are needed to gain an understanding of the anomalous heat production. The  $\text{D}_2\text{O}$  used in these experiments was obtained from NRL and from the same lot number that gave the foaming problem. Foaming did not appear to be a problem in the two experiments run in the sensitive calorimeters. The lithium used, however, was from a different

source (FMC) than the lithium used where foaming was a problem. Studies at the University of Utah using D<sub>2</sub>O from this same lot number also did not show any foaming problem. Perhaps the foaming was due to contamination of an isolated bottle of D<sub>2</sub>O that was used to make up the LiOD solutions. Problems with foaming of D<sub>2</sub>O-LiOD solutions have been reported by other investigators in this field and can, at times, be quite serious.

### SUGGESTED PROCEDURES FOR EXCESS-HEAT PRODUCTION

The first consideration is the selection of an adequate calorimeter to detect any excess power. The calorimeter must be capable of measuring excess power in the range of 1 W per cm<sup>3</sup> of the palladium cathode used. Table 9 presents expected excess-power levels for cathodes of various diameters and a length of 2.0 cm. A good choice would be the selection of a 4-mm-diameter cathode with a 2.0 cm length that would yield about 250 mW of excess power. The use of 1-mm-diameter wires would require very accurate calorimetry to detect the small levels of excess power expected.

The second consideration would be the testing of a variety of palladium or palladium alloy materials. Based on our experiments, Pd-B alloys should be included in these materials. Furthermore, cathodes that do not yield excess power on the first run should be tested a second time. Materials that show excess power should also undergo further testing in repeated experiments. All cathode materials should show smooth surfaces free from cracks and other defects. Careful examination of the electrode surface prior to an experiment can help avoid wasting valuable time investigating flawed materials.

TABLE 9. Excess Power Expected for Various Electrode Sizes Assuming an Excess Power Density of 1 W/cm<sup>3</sup> of Palladium.

Diameter, mm	Area, cm <sup>2</sup>	P <sub>x</sub> , W
1	0.64	0.016
2	1.29	0.063
3	1.95	0.141
4	2.64	0.251
6	4.05	0.565

NOTE: Palladium rods are 2.0 cm long. CalTech study: V = 0.073 cm<sup>3</sup> (0.21 × 2.1 cm). MIT study: V = 0.071 cm<sup>3</sup> (0.1 × 9 cm). Must scale cathode to yield P<sub>x</sub> of 3 σ or larger above calorimetric error.

NAWCWPNS, 1σ=±0.02 W.

Experiments should be run for an adequate period of time. Any excess enthalpy will generally be

measurable within 2 to 3 weeks of the start of the experiment. However, some experiments required 6 weeks of electrolysis before any anomalous heat was detected. In general, 6 to 8 weeks of electrolysis should be allowed before judging that an experiment failed to produce excess power.

Current densities of 100 mA/cm<sup>2</sup> or larger should be used during the experiments. Smaller current densities (20 to 50 mA/cm<sup>2</sup>) can be used during the first week of the experiment. Changing the current density during the experiment may help to trigger the excess-heat effect. Low-current densities and cool-cell temperatures are likely favorable for deuterium loading early in the experiment where the loading process is exothermic. Higher cell temperatures will likely favor higher loading after formation of Pd D<sub>0.6</sub> where the loading process apparently becomes endothermic (References 14 and 32).

A large stock of D<sub>2</sub>O and lithium would be desirable to ensure that these variables remain constant for a series of experiments. Our experiments, however, have shown excess-power effects using a variety of D<sub>2</sub>O lots and lithium sources. The effects of epoxy and silicon rubber remain undetermined based on our experiments. Our biggest excess power effect came from an experiment where epoxy was used. It would probably be wise to use a D<sub>2</sub>O bubbler between the cell and oil bubbler. Some of our best results, however, were obtained in cells that vented the electrolysis gases directly into the atmosphere. General experimental procedures are presented elsewhere (Reference 33).

In summary, the selection of a calorimeter capable of measuring 1 W per cm<sup>3</sup> of the cathode, the testing of a variety of cathode materials over 6 to 8 weeks of electrolysis, and the use of high-current densities after the initial loading should yield some experiments that show anomalous heat production.

## DISCUSSION

Most of the palladium materials investigated at China Lake are summarized in Table 10. Distinct groupings of the success ratio are readily apparent based on the source of the palladium material. A high-success ratio is found for Johnson-Matthey materials where 17 out of 28 studies gave excess heat. The highest success ratio is for NRL Pd-B materials that showed excess power in seven out of eight experiments. Other NRL materials, however, gave poor results, such as NRL Pd-Ag (0/3) and NRL Pd (1/6). The single excess-heat result for NRL Pd involved a second run of the same cathode. Several other Pd and Pd-Ag sources failed to yield any excess heat-producing experiments. This polarization of successful experiments according to the palladium source would be very difficult to explain by random calorimetric errors. These results indicate that the metallurgical preparation of palladium is a major factor for observation of the excess enthalpy effect. A similar conclusion concerning reproducibility of the excess-power production has been reported by McKubre et al. (Reference 1) Our results suggest that the presence of B within the palladium may be a critical variable.

TABLE 10. Summary of Palladium Materials Tested for Excess Power.

Source	d, cm	V, cm <sup>3</sup>	P <sub>x</sub> /V, W/cm <sup>3</sup>	Success ratio
NRL Pd-B (0.75%)	0.6	0.57	0.6	2/2
NRL Pd-B (0.75%)	0.25	0.12	2.1	1/2 (7/8)
NRL Pd-B (0.50%)	0.40	0.25	0.4	2/2
NRL Pd-B (0.25%)	0.40	0.25	0.8	2/2
JM Pd	0.63	0.36	1.4	9/14
JM Pd	0.63	0.67	0.3	1/1
JM Pd JM	0.40	0.20	0	0/2 (17/28)
(F/P) Pd	0.20	0.038	3.1	1/1
JM (F/P) Pd	0.10	0.012	14.0	1/1
JM Pd	0.10	0.02	15.0	3/7
JM Pd-Ce (F/P)	0.41	0.25	1.1	2/2
NRL Pd	0.40	0.25	0.4	1/2 (2/5)
Tanaka Pd (Sheet)	...	0.05	1.2	1/3
NRL Pd	0.40	0.25	0	0/4
NRL Pd-Ag	0.42	0.21	0	0/3
IMRA Pd-Ag	0.40	0.20	0	0/2 (0/19)
WESGO Pd (1989)	0.14	0.09	0	0/6
Pd/Cu	(0.63)	0.02	0	0/2
John Dash Pd (sheet)	...	0.04	0	0/2
Co-deposition (1992)	(0.63)	0.002	75	2/34

The total excess enthalpy observed in various experiments is presented in Table 11. These values range up to 1,400 kJ for the longest periods of excess power. The complete combustion of all palladium within the cell and all the absorbed deuterium would only yield 6 to 7 kJ for the mass of palladium used, thus chemical reactions cannot explain the total excess enthalpy that was measured (Reference 33).

Our results present a striking correlation between the measured excess power and helium production in D<sub>2</sub>O-LiOD electrolysis cells using palladium cathodes (Reference 25). The measured rate of helium production (1011 to 1012 <sup>4</sup>He/s W) is the correct magnitude for typical fusion reactions that yield helium as a product.

TABLE 11. Total Excess Enthalpy in Various Experiments.

Year	Cathode	Excess enthalpy, kJ	Days / cell	Comments
1989	JM Pd (6.35 mm)	210	26/B	
1989	JM Pd (6.35 mm)	220	26/A	
1989	JM Pd (6.35 mm)	300	38/A	
1990	JM Pd (6.35 mm)	1,400	83/A	Helium, glass flasks, U of Texas
1991	JM Pd (6.35 mm)	48	11/B	Helium, glass flasks, Rockwell
1992	JM Pd (1 mm)	290	66/B	Helium, metal flasks, DOI <sup>a</sup>
1994	NRL Pd-B (6 mm)	950	137/B	Helium, metal flasks, DOI <sup>a</sup>



<sup>a</sup> Helium analysis by the Department of Interior (DOI) Laboratory, Amarillo, Texas.

Three sets of heat and helium measurements have yielded similar results. Our first experiments (1990 to 1991) using Pyrex glass flasks resulted in eight experiments that yielded heat and helium, and six experiments that gave no excess power and no detectable helium. The helium measurements were performed at the University of Texas. Our second set of experiments (1991 to 1992) also used Pyrex glass flasks and involved three experiments that produced excess power and helium. The helium measurements were done by Rockwell International. Our final set of experiments (1993 to 1994) used metal flasks. Six experiments produced no excess power and only background levels of helium (Table 2). Seven experiments yielded excess power and helium production (Table 3). The helium measurements were performed by the U.S. Bureau of Mines, Amarillo, Texas.

The probability that all three sets of heat and helium measurements using palladium cathodes could be due to random errors is given by

$$P = P_1 * P_2 * P_3 = \left(\frac{1}{2}\right)^{14} * \left(\frac{1}{2}\right)^3 * \left(\frac{1}{2}\right)^{13} = \frac{1}{1,073,741,800} \quad (8)$$

It is highly unlikely that our thirty experiments involving excess power and helium measurements could produce such consistent results due to random errors. There was only one valid experiment that yielded excess power but no helium above normal background levels. This was the Pd-Ce study shown in Figure 18, along with the two helium measurements presented in Table 5.

The inclusion of the two helium measurements for the Pd-Ce cathode (Table 5), along with the flawed excess heat measurement due to the low D<sub>2</sub>O level (sample 12/17/90-B,

References 14 through 16), still yields an overwhelming probability against random errors expressed by

$$P = \frac{33!}{30!3!} \left(\frac{1}{2}\right)^{30} * \left(\frac{1}{2}\right)^3 = \frac{1}{1,574,402} \quad (9)$$

This calculation is for three mismatches, assuming a probability of exactly one-half for observing either excess heat or excess helium in any given sample.

The odds are, therefore, approximately one in a million that our complete set of 33 heat and helium results could be obtained from random experimental errors in our calorimetry and helium measurements. A more rigorous treatment in Appendix C gives the probability as one out of 750,000 for our set of 33 heat and helium results. Permanent laboratory records always defined the presence or absence of excess power prior to the helium measurements. Critics should carefully consider the probabilities presented in Equations 8 and 9 before dismissing this new science of anomalous effects in deuterated materials (Reference 34).

Significant levels of  $^4\text{He}$  in deuterated palladium systems have also been reported by several other laboratories (Reference 22). These studies all agree with our initial report that the major fusion product is  $^4\text{He}$  rather than  $^3\text{He}$  (Reference 15). A recent study involving bombardment of palladium and titanium immersed in  $\text{D}_2\text{O}$  with intense ultrasound produced  $^4\text{He}$  levels greater than the normal atmospheric concentration (Reference 35). We report 18 experiments with excess power and elevated helium levels, along with 12 experiments showing no excess power and no excess helium. To our knowledge, there are no experimental errors that can explain these results.

Although radiation monitoring was a minor part of our program, the anomalous radiation observed in some experiments cannot be explained by any known error source. Anomalous radiation was detected by X-ray film exposure, by the use of several different GM detectors, and by the use of NaI detectors. There was never any anomalous radiation when the experiments were not running. Many experiments showed no unusual radiation counts. Anomalous radiation appeared within a few hours in co-deposition experiments where deuterium loading is rapid (Figure 8). The anomalous radiation always appeared much later when solid palladium or palladium alloy cathodes was used (Figure 13). Similar radiation effects have been reported by S. Szpak et al. (Reference 28).

There was never any significant production of tritium in any of our experiments. A few experiments suggested low levels of tritium production (Table 1, see also Reference 22).

Progress on this program was hindered by two major approaches that failed to produce reproducible excess-heat effects. The first approach was the co-deposition method. Based on the small amount of palladium present in these experiments, excess heat could not be readily measured by our normal calorimetry. Nevertheless, carefully controlled plating processes in  $\text{D}_2\text{O}$  offer the possibility of reproducible palladium surfaces already loaded with deuterium that could yield anomalous effects without the long electrolysis times required for palladium rods (Reference

28). Further studies of this method using more sensitive calorimeters are warranted.

The second approach that hindered progress was the extended focus on NRL Pd-Ag and Pd cathodes. The deuterium loading was poor for these materials, hence excess-heat production was not likely. This is exactly what was observed by our calorimetric experiments. Success with NRL materials was finally achieved for Pd-B alloys, but these results apparently came too late to save this program. Even the NRL Pd-B materials often showed folded-over metal regions or other flaws that would likely act as cracks and prevent high loadings. Our calorimetry generally yielded excess enthalpy when palladium samples that yielded excess heat at other laboratories were tested and never yielded excess heat when samples that contained flaws or that showed poor loading characteristics were tested.

Some comments are necessary concerning the major disappointment that no excess power was measured in experiments conducted at NRL (Reference 36). The calorimeters at NRL were modified into a larger design to permit loading studies. This obviously changed the scaling of the cell, which is an important factor in these experiments (Reference 5). Furthermore, the room temperature control was very poor in the laboratory at NRL. Finally, the data acquisition system used at NRL did not average the cell potential. This large error source ( $\pm 5\%$ ) is discussed on page 9. These factors led to a reported error of  $\pm 200$  mW or larger ( $\pm 10\%$ ) in experiments at NRL (Reference 36). Any excess power effect at NRL would have to be at least 600 mW to be clearly beyond experimental error. The excess-power effects observed at China Lake during this program would not have been detectable at NRL. As discussed previously, the calorimetry used in these experiments must be capable of readily detecting excess-power levels of 1 W per  $\text{cm}^3$  of the palladium cathode (see Table 9). It should also be noted that the NRL calorimeters were primarily used to study NRL-prepared Pd-Ag and Pd materials. We never observed excess power in our studies of these same materials except for the single case of running an NRL Pd cathode a second time. No calorimetric studies of the promising Pd-B materials were completed at NRL. During the last year of this program, a very sensitive Seebeck calorimeter was placed in operation at NRL. Due to various problems, no valid experiment was completed at NRL using this new calorimetry. In conclusion, the calorimetric effort at NRL was indeterminate. No excess power was detected, but there were also no calorimetric experiments completed that were capable of measuring the levels of excess power obtained at China Lake. Thus the ratio of excess heat producing experiments at NRL to the number of valid experiments capable of detecting excess-power levels of 1 W per cubic centimeter of palladium was 0/0 or indeterminate.

## SUMMARY

This field of anomalous effects in a deuterated system, which has come to be called “cold fusion,” is a far more difficult research area than we might have thought 7 years ago. Progress at various laboratories around the world has not been as rapid as one might have hoped. Two technically challenging problems restrict progress (Reference 1):

1. Irreproducibility
2. Scarcity of energetic (nuclear) products.

Although we have not succeeded in solving the Reproducibility problem, our results indicate that helium-4 is the missing nuclear product. This  $^4\text{He}$  is the most likely nuclear product that could have remained so well hidden during the past 7 years.

The remarkable correlation of excess power with the source of palladium in Table 10 cannot be easily explained by any calorimetric errors. Furthermore, 30 experiments at our laboratory have shown a correlation between either excess power and helium production or no excess power and no excess helium. It is highly unlikely that our heat and helium correlations could be due to random errors. Finally, our calorimetric results, conclusions, and problems are practically identical to those reported by the SRI laboratory (Reference 1). In our opinion, these factors provide compelling evidence that the anomalous effects measured in deuterated systems are real. Appendix D summarizes our experimental results that support this conclusion.

This research area has the potential to provide the human race with a nearly unlimited new source of energy. We hope that other scientists will continue to investigate this difficult research area until the challenging problems impeding progress are solved. It is still possible that anomalous effects in deuterated systems will prove to be one of the most important scientific discoveries of this century.

## REFERENCES

1. M. C. H. McKubre, S. Crouch-Baker, A. K. Hauser, S. I. Smedley, F. L. Tanzella, M. S. Williams, and S. S. Wing. "Concerning Reproducibility of Excess Power Production," in *Proceedings of the Fifth International Conference on Cold Fusion, 9-13 April 1995, Monte Carlo, Monaco*, pp. 17-33.
  2. M. C. H. McKubre, S. Crouch-Baker, R. C. Rocha-Filho, S. I. Smedley, and F. L. Tanzella, "Isothermal Flow Calorimetric Investigations of the D/Pd and H/Pd Systems," *J. Electroanal. Chem.*, Vol. 368 (1994), pp. 55-66.
  3. D. E. Stilwell, K. H. Park, and M. H. Miles. "Electrochemical Calorimetric Studies on the Electrolysis of Water and Heavy Water (D<sub>2</sub>O)," *J. Fusion Energy*, Vol. 9 (1990), pp. 333-6.
  4. M. H. Miles, K. H. Park, and D. E. Stilwell. "Electrochemical Calorimetric Evidence for Cold Fusion in the Palladium-Deuterium System," *J. Electron Chem.*, Vol. 296 (1990), pp. 241-54.
- M. Fleischmann, S. Pons, M. W. Anderson, L. J. Li, and M. Hawkins." Calorimetry of the Palladium-Deuterium-Heavy Water System," *J. Electroanal. Chem.*, Vol. 287 (1990), pp. 293-348.
6. M. H. Miles, G. S. Ostrom, B. F. Bush, and J. J. Lagowski. "Experimental Evidence for Correlated Heat and Helium Production in Cold Fusion Experiments," in *Proceedings of the Symposium on Hydrogen Storage Materials, Batteries, and Electrochemistry, Vol. 92-5*, ed. by D. A. Corrigan and S. Srinivasan. Pennington, N.J., The Electrochemical Society, Inc., 1992. Pp. 287-97.
  7. E. Storms. "Review of Experimental Observations About the Cold Fusion Effect," *Fusion Tech.*, Vol. 20 (1991), pp. 433-77.
  8. "Cold Fusion Research. A Report of the Energy Research Advisory Board to the United States Department of Energy," John Huizenga and Norman Ramsey, Co-chairmen, November 1989, p. 12.
  9. M. H. Miles, K. H. Park, and D. E. Stilwell. "Electrochemical Calorimetric Studies of the Cold Fusion Effect," in *Proceedings of the First Annual Conference on Cold Fusion, 1990, Salt Lake City, Utah*. Pp. 328-34.
  10. M. C. H. McKubre, S. Crouch-Baker, A. M. Riley, S. I. Smedley, and F. L. Tanzella. "Excess Power Observations in Electrochemical Studies of the D/Pd System: the Influence of Loading," in *Frontiers of Cold Fusion*, ed. by H. Ikegami. Tokyo, Universal Academy Press, 1993. Pp. 5-19.
  11. S. E. Jones and L. D. Hansen, "Examination of Claims of Miles et al. in Pons-Fleischmann-Type Cold Fusion Experiments," *J. Phys. Chem.*, Vol. 99 (1995), pp. 6966-72.

12. J. E. Jones, L. D. Hansen, S. E. Jones, D. S. Shelton, and J. M. Thorne. "Faradaic Efficiencies Less Than 100% During Electrolysis of Water Can Account for Reports of Excess Heat in Cold Fusion Cells," *J. Phys. Chem.*, Vol. 99 (1995), pp. 6973-9.
13. M. H. Miles, B. F. Bush, and D. E. Stilwell. "Calorimetric Principles and Problems in Measurements of Excess Power During Pd-D<sub>2</sub>O Electrolysis," *J. Phys. Chem.*, Vol. 98 (1994), pp. 1948-1952. See also M. H. Miles and B. F. Bush. "Calorimetric Principles and Problems in Pd-D<sub>2</sub>O Electrolysis" in *Frontiers of Cold Fusion*, ed. by H. Ikegami, Tokyo, Universal Academy Press, 1993. Pp. 189-99.
14. M. H. Miles, R. A. Hollins, B. F. Bush, J. J. Lagowski, and R. E. Miles, "Correlation of Excess Power and Helium Production During D<sub>2</sub>O and H<sub>2</sub>O Electrolysis Using Palladium Cathodes," *J. Electroanal. Chem.*, Vol. 346 (1993), pp. 99-117.
15. B. F. Bush, J. J. Lagowski, M. H. Miles, and G. S. Ostrom. "Helium Production During the Electrolysis of D<sub>2</sub>O in Cold Fusion Experiments," *J. Electroanal. Chem.*, Vol. 304 (1991), pp. 271-8.
16. M. H. Miles, B. F. Bush, G. S. Ostrom, and J. J. Lagowski. "Heat and Helium Production in Cold Fusion Experiments," in *The Science of Cold Fusion. Proceedings of the Second Annual Conference on Cold Fusion*, ed. by T. Bressani, E. Del Giudice and G. Preparata. Bologna, Italy, Italian Physical Society, 1991. Pp. 363-72.
17. M. Srinivasan. "Nuclear Fusion in an Atomic Lattice: An Update on the International Status of Cold Fusion Research," *Current Science*, Vol. 60 (1991), pp. 417-39.
18. M. H. Miles and R. E. Miles, "Theoretical Neutron Flux Levels, Dose Rates, and Metal Foil Activation in Electrochemical Cold Fusion Experiments," *J. Electroanal Chem.*, Vol. 295 (1990), pp. 409-14.
19. T. A. Chubb and S. R. Chubb. "Cold Fusion as an Interaction Between Ion Band States," *Fusion Technol.*, Vol. 20 (1991), pp. 93-99. See also S. R. Chubb and T. A. Chubb. "Ion Band-State Fusion: Reactions, Power Density, and the Quantum Reality Question," *Fusion Technol.*, Vol. 24 (1993), pp. 403-16.
20. E. Pennisi, "Helium Find Thaws the Cold Fusion Trail," *Science News*, Vol. 139 (23 Mar 1991), p. 180.
21. R. Dagani. "New Evidence Claimed for Nuclear Process in Cold Fusion," *Chem. Eng. News*, 1 April 1991, pp. 31-3.
22. M. H. Miles, B. F. Bush, and J. J. Lagowski. "Anomalous Effects Involving Excess Power, Radiation, and Helium Production During D<sub>2</sub>O Electrolysis Using Palladium Cathodes," *Fusion Technol.*, Vol. 25 (1994), pp. 478-86.

23. M. H. Miles and B. F. Bush, "Search for Anomalous Effects Involving Excess Power and Helium During D<sub>2</sub>O Electrolysis Using Palladium Cathodes," in *Frontiers of Cold Fusion*, ed. by H. Ikegami. Tokyo, Universal Academy Press, 1993. Pp. 189-99.
24. M. H. Miles and B. F. Bush, "Heat and Helium Measurements in Deuterated Palladium," in *Proceedings: Fourth Intentional Conference on Cold Fusion. Volume 2: Calorimetry and Materials Papers, Report No. EPRI TR-104188Volume 2*, Palo Alto, Calif., Electric Power Research Institute, July 1994. Pp. 6.16.7.
25. M. H. Miles and B. F. Bush. "Heat and Helium Measurements in Deuterated Palladium," *Transactions of Fusion Technol.*, Vol. 26 (December 1994), pp. 156-9.
26. S. Szpak, P. A. Mosier-Boss and J. J. Smith. "On the Behavior of Pd Deposited in the Presence of Evolving Deuterium," *J. Electroanal. Chem.*, Vol. 302 (1991), pp. 255-60.
27. H. Uchida, Y. Hamada, Y. Matsumura, and T. Hayashi. "Detection of Radioactive Emissions in the Electrolytic Deuteriding -- Dedeuteriding Reactions of Pd and Ti," in *Frontiers of Cold Fusion*, ed. by H. Ikegami. Tokyo, Universal Academy Press, 1993. Pp. 539-42.
28. S. Szpak, P. A. Mosier-Boss, and J. J. Smith. "On the Behavior of He Cathodically Polarized Pd/D System: Search for Emanating Radiation," *Physics Letters A*, Vol. 210(1996), pp. 382-90. See also Naval Command, Control and Ocean Surveillance Center-Naval Research and Development. *Anomalous Behavior of the PAID System*, by S. J. Szpak and P. A. Mosier-Boss. San Diego, Calif., NCCOSC-NRaD, September 1995. 180 pp. (NCCOSC NRaD Technical Report 1696, publication UNCLASSIFIED.)
29. S. Szpak, P. A. Mosier-Boss, and J. J. Smith. "Comments on Methodology of Excess Tritium Determinations," in *Frontiers of Cold Fusion*, ed. by H. Ikegami, Tokyo, Universal Academy Press, 1993. Pp. 515-8.
30. A. Takahashi, A. Mega, T. Takeuchi, H. Miyamaru, and T. Iida "Anomalous Excess Heat by D<sub>2</sub>O/Pd Cell Under L-H Mode Electrolysis," *Frontiers of Cold Fusion*, ed. by H. Ikegami. Tokyo. Universal Academy Press, 1993. Pp. 74-91.
31. B. F. Bush and M. H. Miles. "Practical Aspects of Heat and Helium Measurements in Deuterated Palladium," in *Cold Fusion Source Book, Proceedings of the International Symposium on Cold Fusion and Advanced Energy Sources*, ed. by H. Fox. Minsk, Belarus, 24-26 May 1994. See also *Cold Fusion Symposium*, Minsk, 1994, pp. 349-356.
32. J. Balej and J. Divisek. "Energy Balance of D<sub>2</sub>O Electrolysis with a Palladium Cathode, Part I. Theoretical Relations," *J. Electroanal Chem.*, Vol. 278 (1989), pp. 85-98.
33. M. H. Miles. "The Extraction of Information From an Integrating Open Calorimeter in Fleischmann-Pons Effect Experiments," in *Proceedings of the Fifth International Conference on*

*Cold Fusion*, 9-13 April 1995, Monte Carlo, Monaco. Pp. 97-104. See also E. Storms. "How to Reproduce the Pons-Fleischmann Effect," *Fusion Tech.*, Vol. 29 (1996), pp. 261-8.

34. M. H. Miles. "Reply to Examination of Claims of Miles et al. in Pons-Fleischmann Type Cold Fusion Experiments," *J. Phys. Chem.* (submitted).

35. R. Stringham and R. George. "Cavitation Induced Solid State Production of Heat,  $^3\text{He}$ , and  $^4\text{He}$ ," in *Book of Abstracts, 209th ACS National Meeting, 2-6 April 1995, Anaheim, Calif., NUCL 044*.

36. Naval Research Laboratory. *A Summary of NRL Research on Anomalous Effects in Deuterated Palladium Electrochemical Systems*, by D. D. Dominguez, P. L. Hagans, and M. A. Imam, Washington, DC, NRL, 9 January 1996. 132 pp. (NRL/MRJ617096-7803, publication UNCLASSIFIED.)

# FIGURES

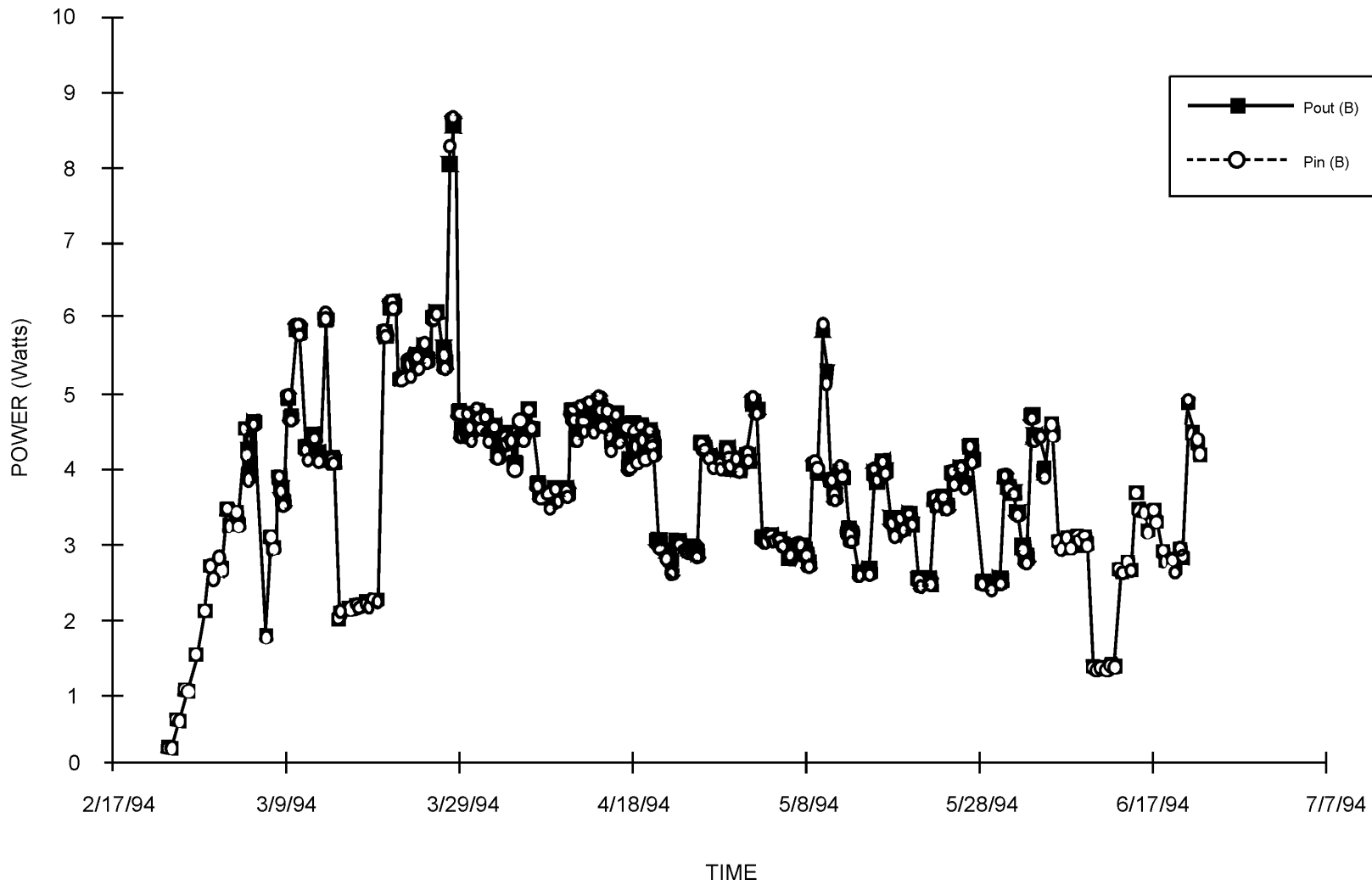

FIGURE 1. Electrochemical Input Power and Calorimetrically Measured Output Power for an NRL Palladium Cathode That Produced No Excess Power, Cell D.

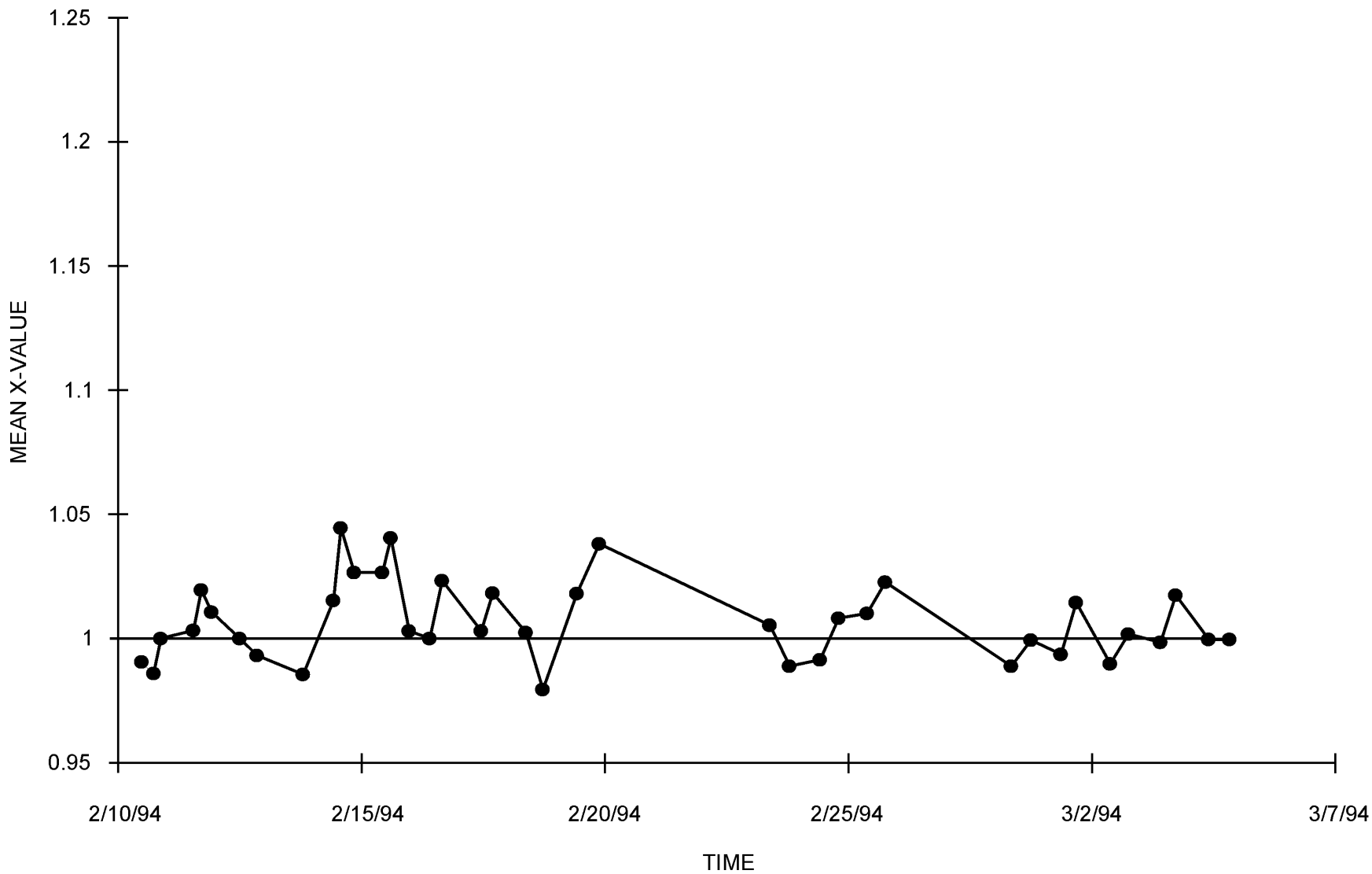

FIGURE 2. Ratio, X, of the Calorimetric Output Power and the Electrochemical Input Power for a Palladium Sheet Cathode Obtained From John Dash (Professor, Portland State University), Cell B. No significant excess power was observed.

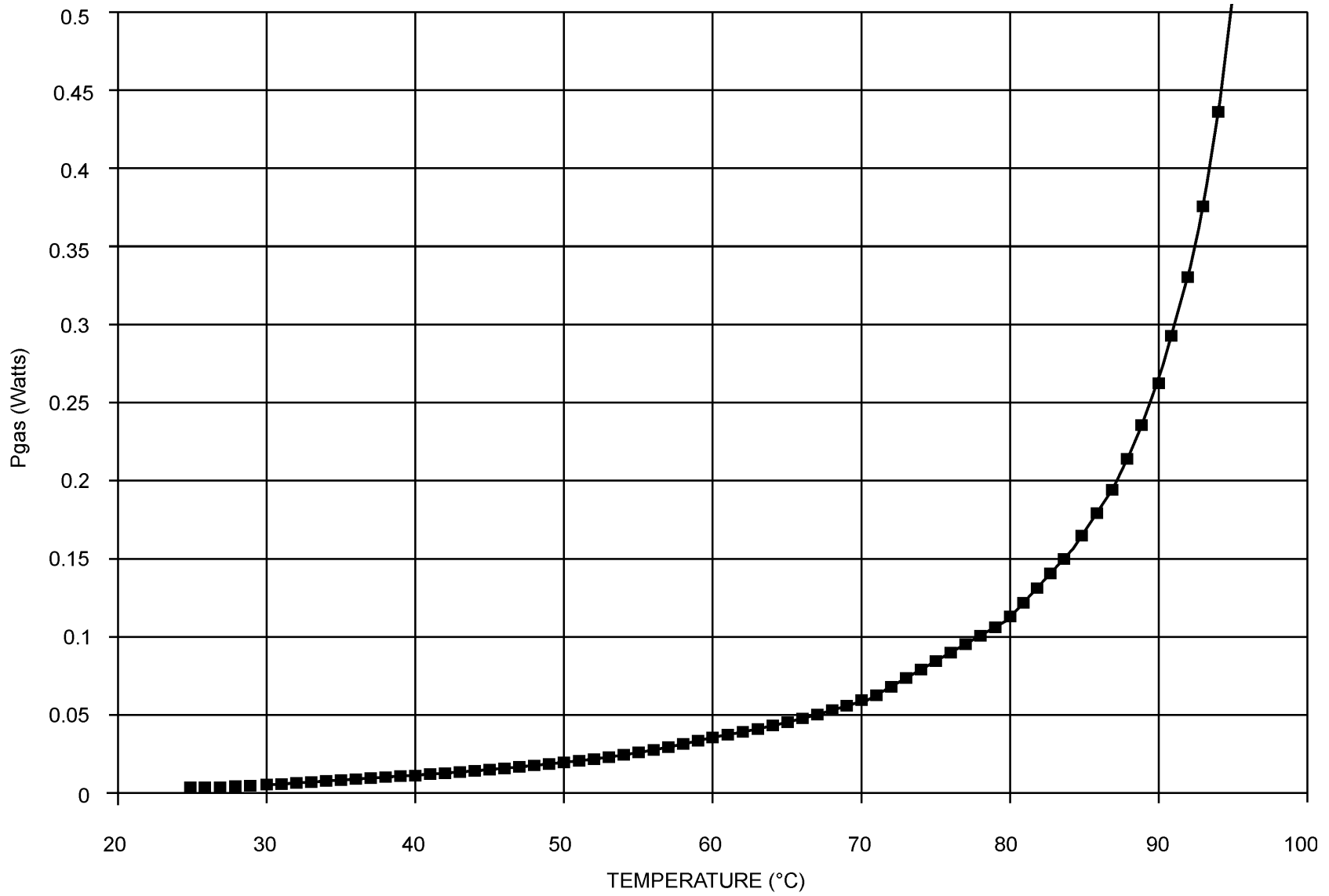
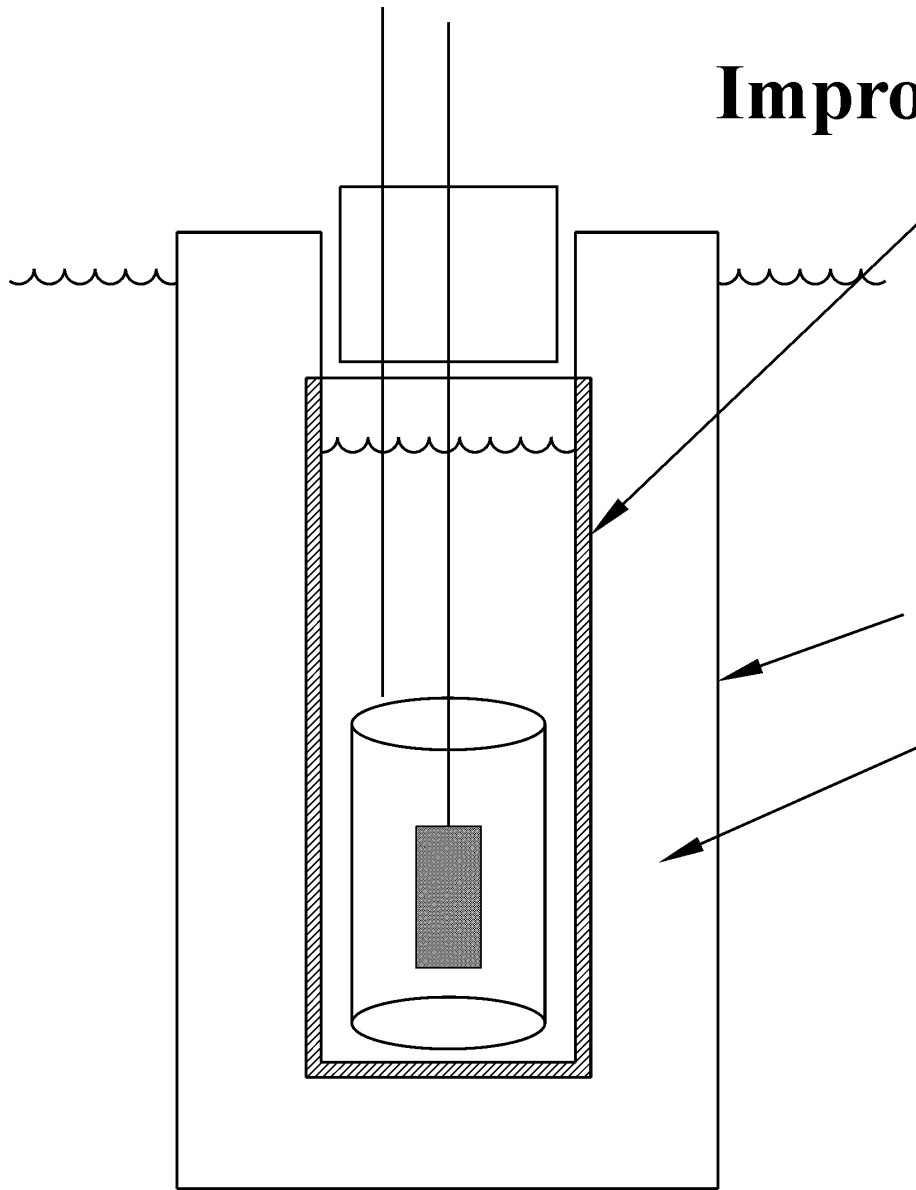

FIGURE 3. Theoretical Effect of the Cell Temperature on the P<sub>gas</sub> Term (Equation 2) When I = 0.500 A and the Bath Temperature is 27.50°C.

# Improved Calorimetry Design



- \* Cu inner jacket replaces H<sub>2</sub>O jacket
  - less variation with electrolyte level
  - improved temperature measurements
- \* Lead wires thermally staked to bath temperature
  - less room temperature effect
  - eliminate thermocouple effect
- \* Cu outer jacket
  - less bath level effects
- \* Foam insulation
  - won't shift or settle
- \* Active cooling of bath
  - maintain bath control at high input power to cells
  
- \* Improved calorimetry while retaining ability to raise cell temperature quickly

FIGURE 4. Improved Design for Integrating Open, Isoperibolic Calorimeters Constructed at China Lake in 1994.

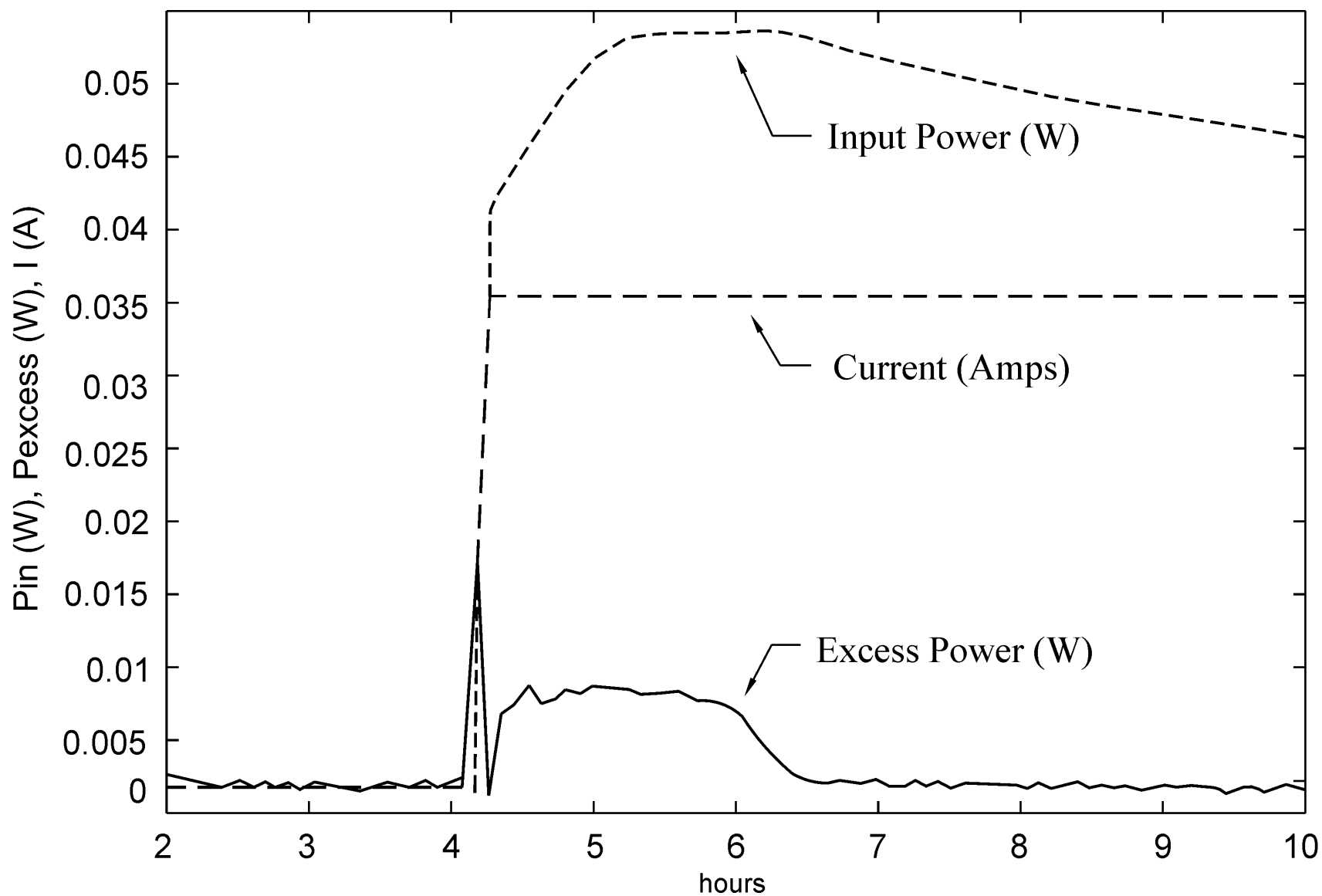

FIGURE 5. Measurement of the Exothermic Heat of Absorption of Deuterium Into a Palladium Wire (1 mm  $\times$  4.3 cm) Using the New Calorimeter Developed at China Lake.

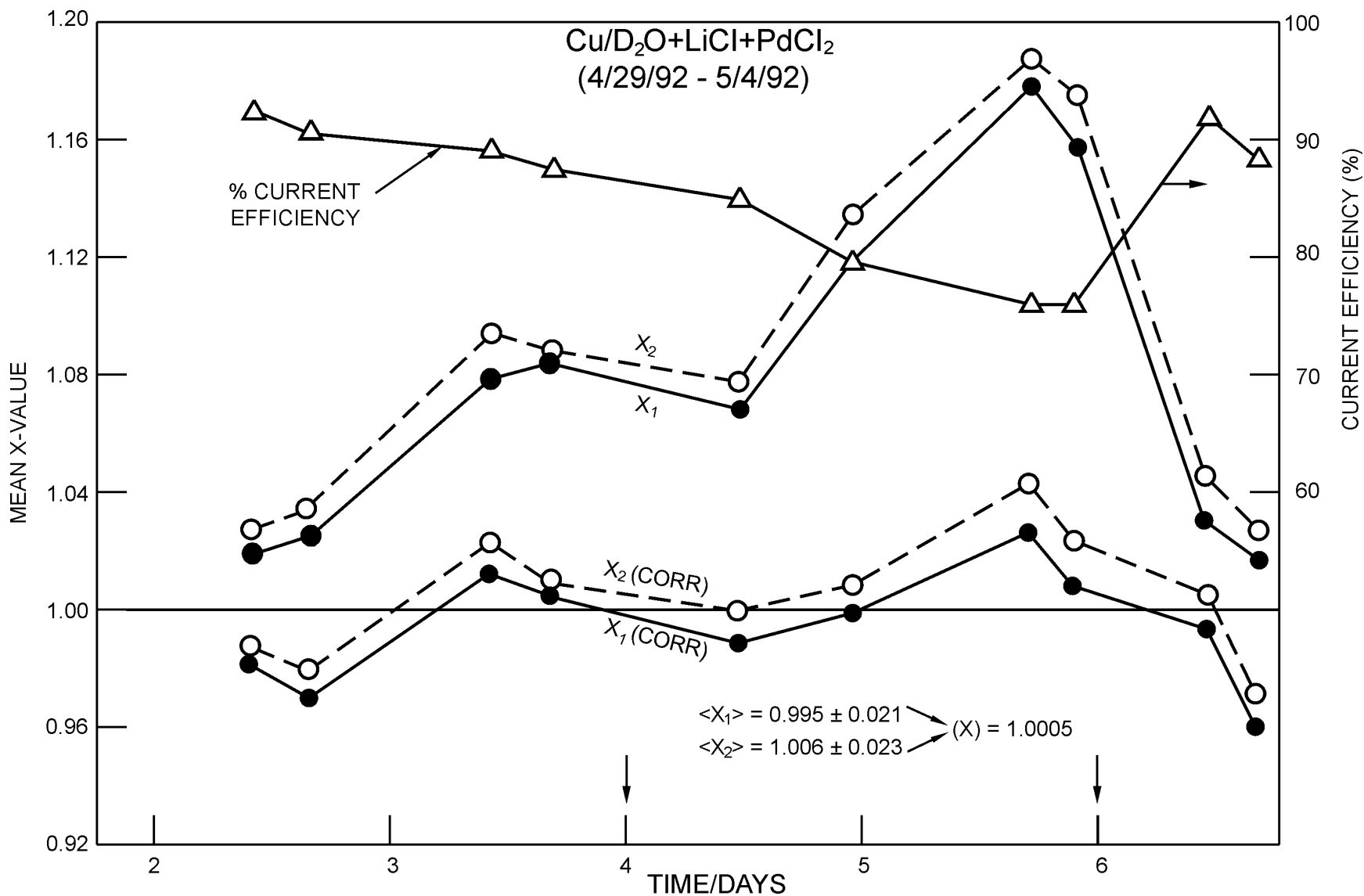

FIGURE 6. Palladium-Deuterium Co-Deposition Experiment Where the Current Efficiency is Significantly Less Than 100%. No significant excess power is observed after correcting for the experimental current efficiency ( $\gamma$ ).

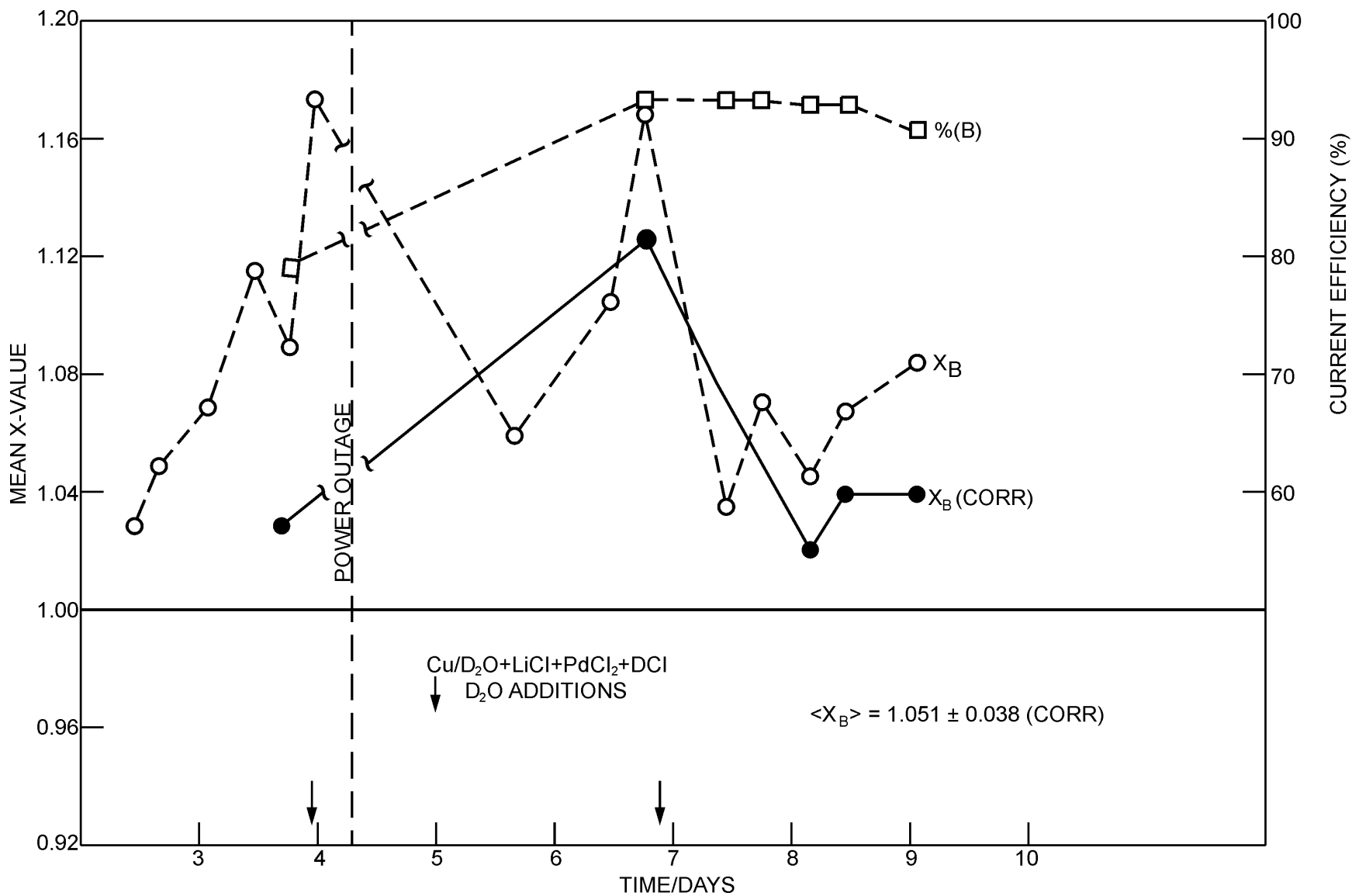

FIGURE 7. Palladium-Deuterium Co-Deposition Experiment Where Significant Excess Power Remains Even After Correcting for the Current Efficiency ( $\gamma$ ).

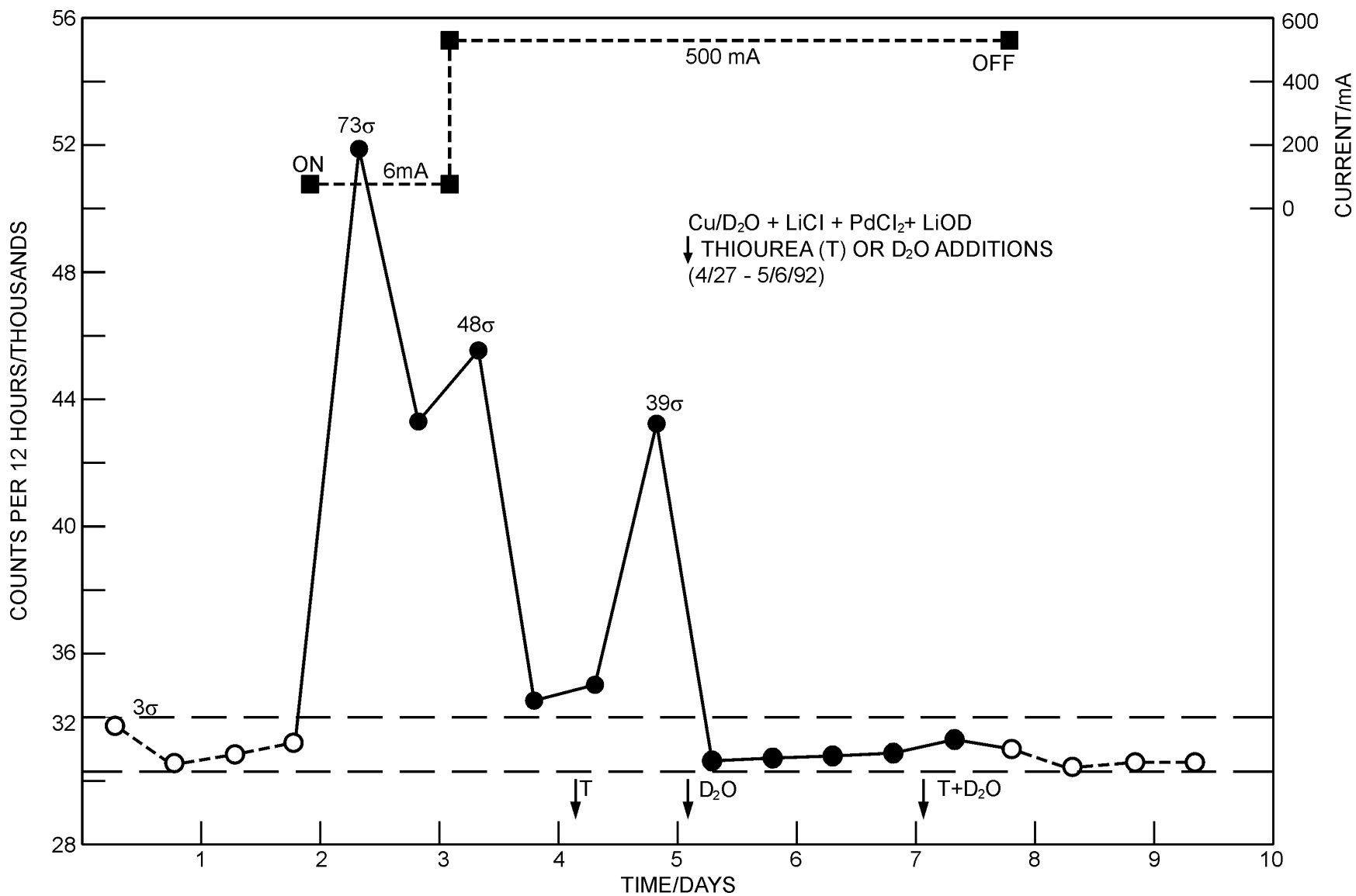

FIGURE 8. Anomalous Radiation Counts Observed During a Palladium-Deuterium Co-Deposition Experiment.

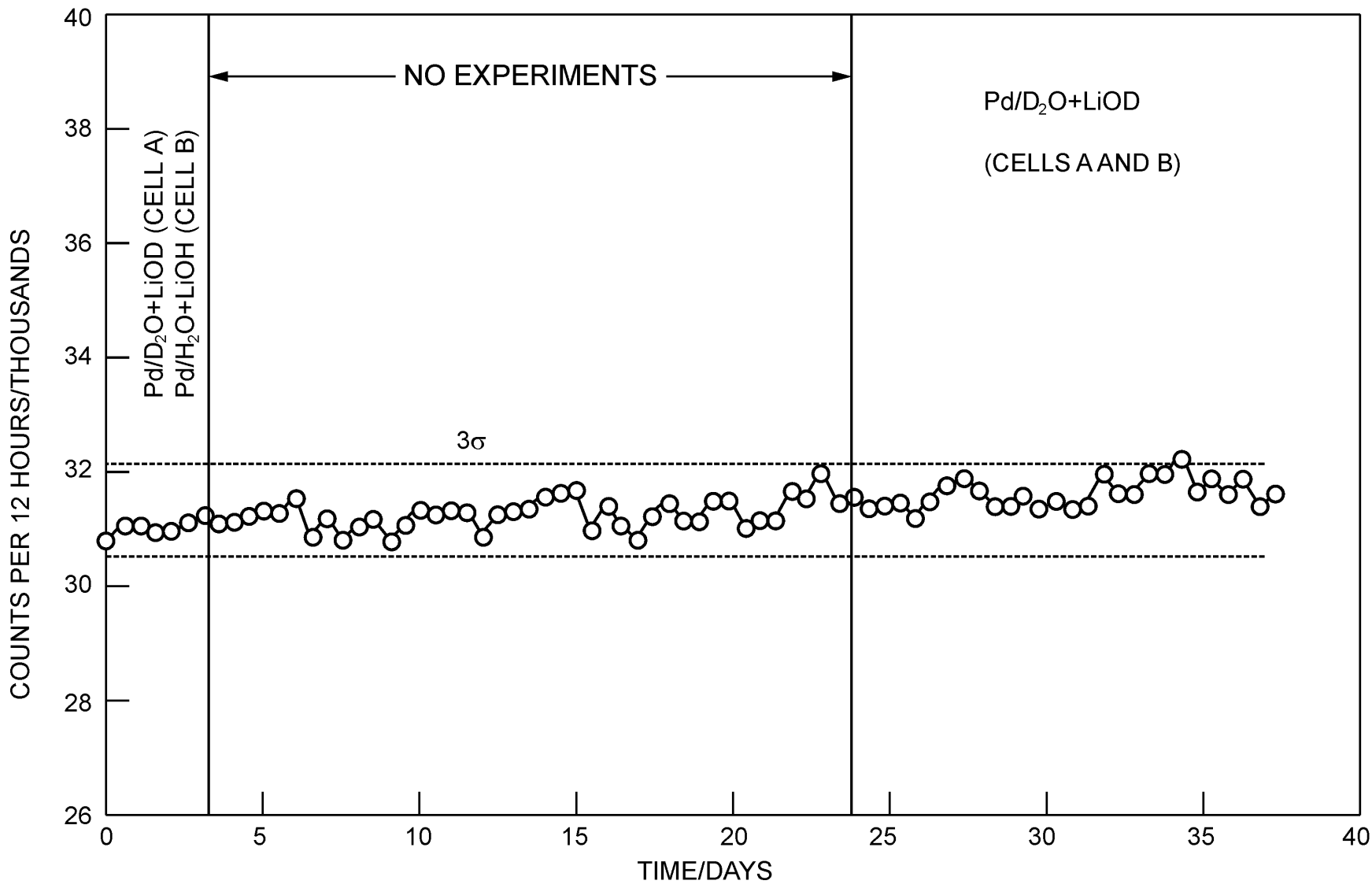

FIGURE 9. Normal Radiation Counts Observed During Periods of Electrolysis Experiments and No Experiments. The same Geiger-Mueller (GM) Detector as in Figure 8 was used.

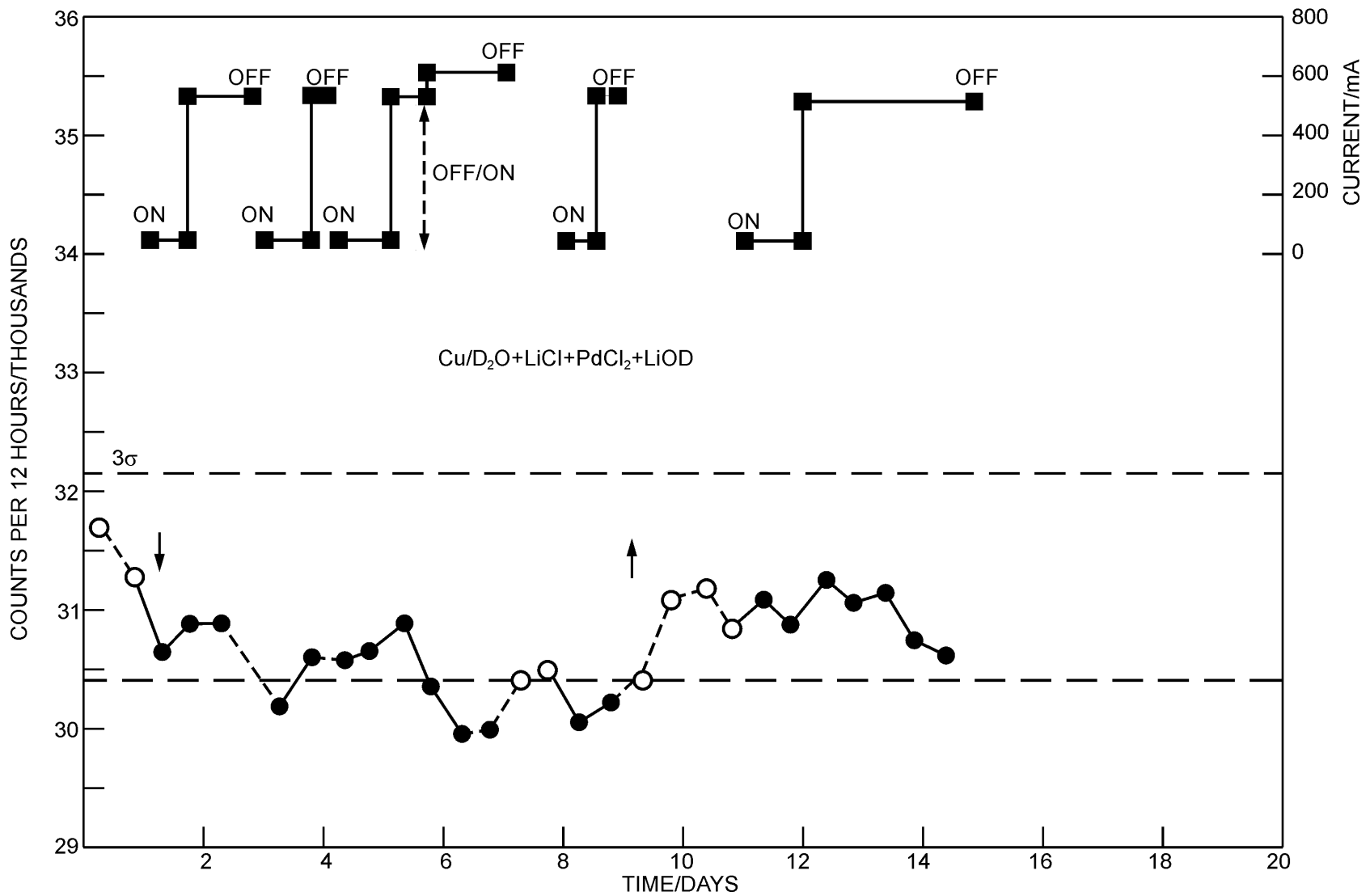

FIGURE 10. Five Successive Palladium-Deuterium Co-Deposition Experiments That Showed No Anomalous Radiation. The same GM Detector as in Figures 8 and 9 was used. NRL X-ray and germanium detectors placed near the cells also showed no anomalous radiation.

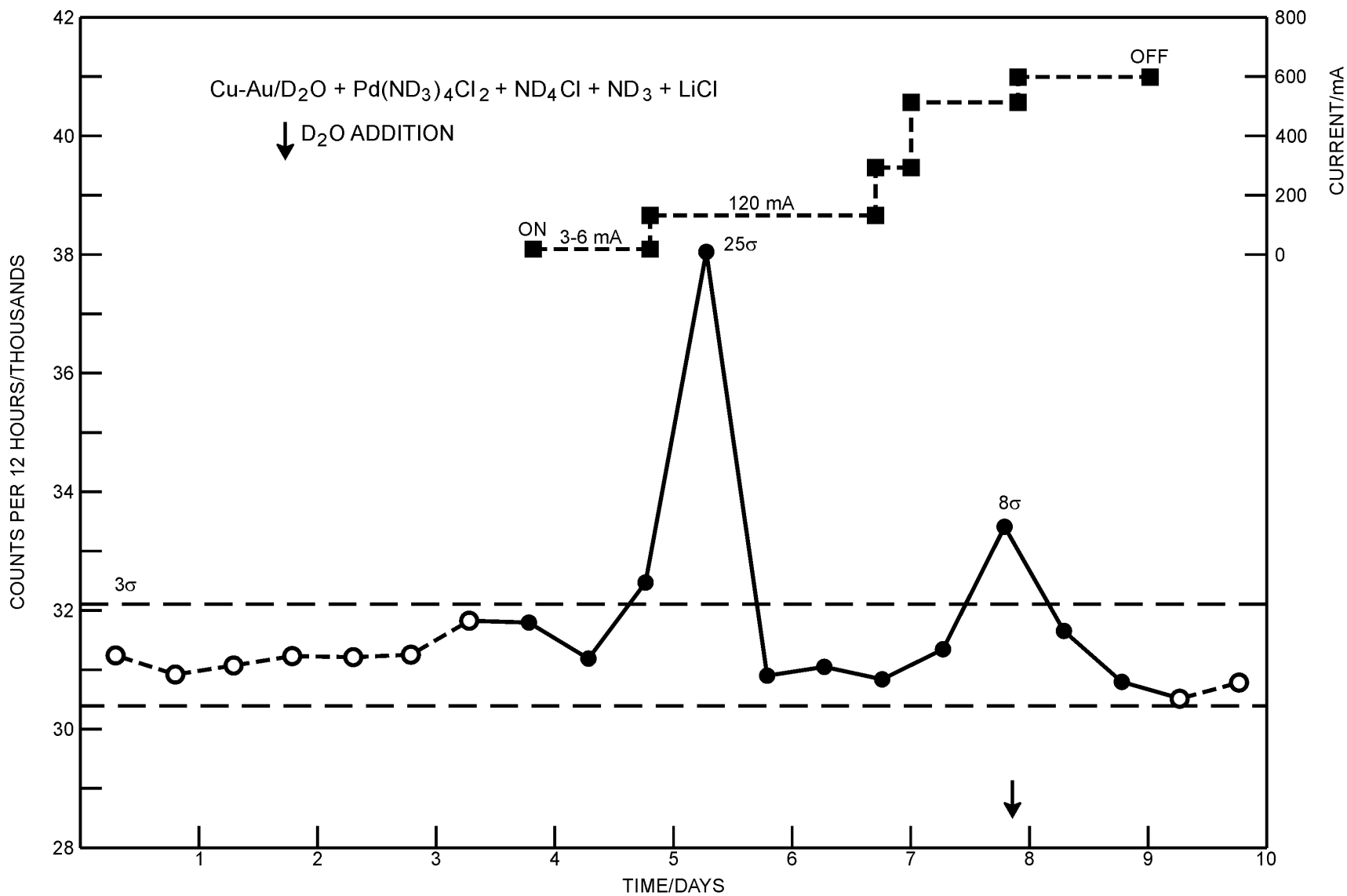

FIGURE 11. Modified Palladium-Deuterium Co-Deposition Experiment Using Palladous Amine Chloride in a ND<sub>4</sub>Cl + ND<sub>3</sub> Buffer Solution. Anomalous radiation was observed using the same GM Detector as in Figures 8-10.

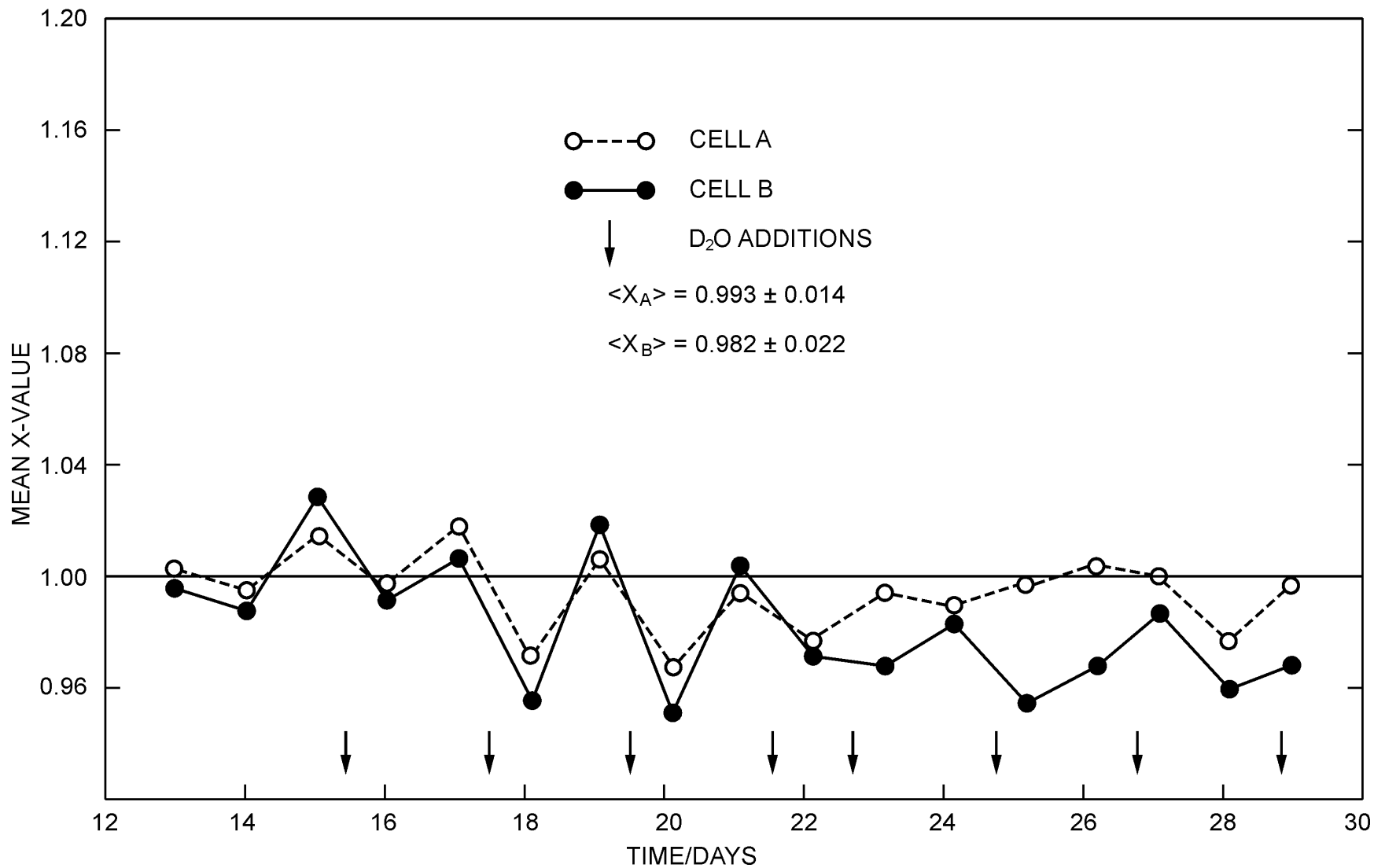

FIGURE 12. Two Calorimetric Studies in Cells A and B of NRL Pd-Ag Alloy Cathodes That Showed No Excess Power.

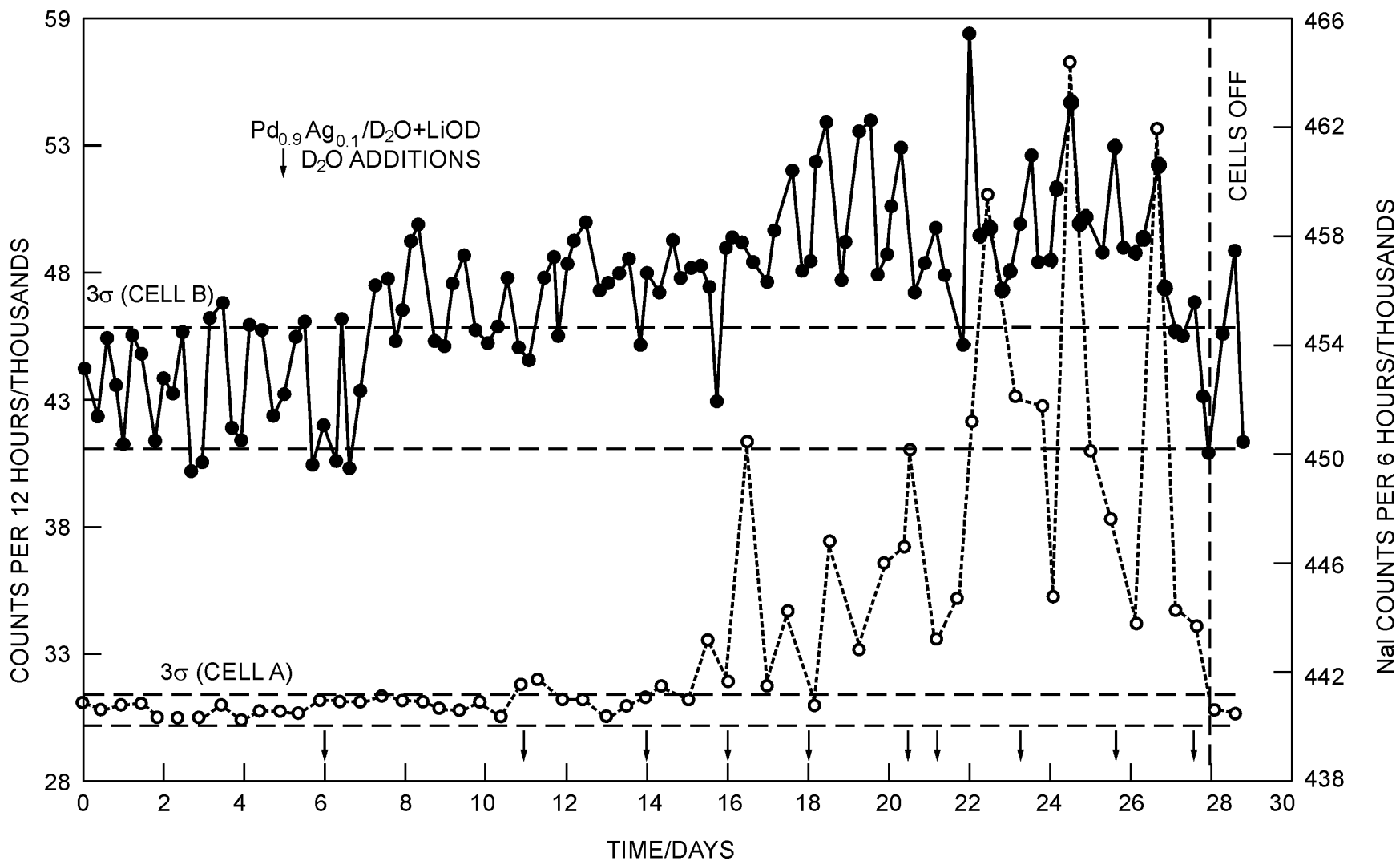

FIGURE 13. Anomalous Radiation During the NRL Pd-Ag Alloy Experiments Using Two Different Detectors. Both the GM detector (bottom curve) and the sodium iodide detector (top curve) show anomalous radiation after 8-15 days of electrolysis.

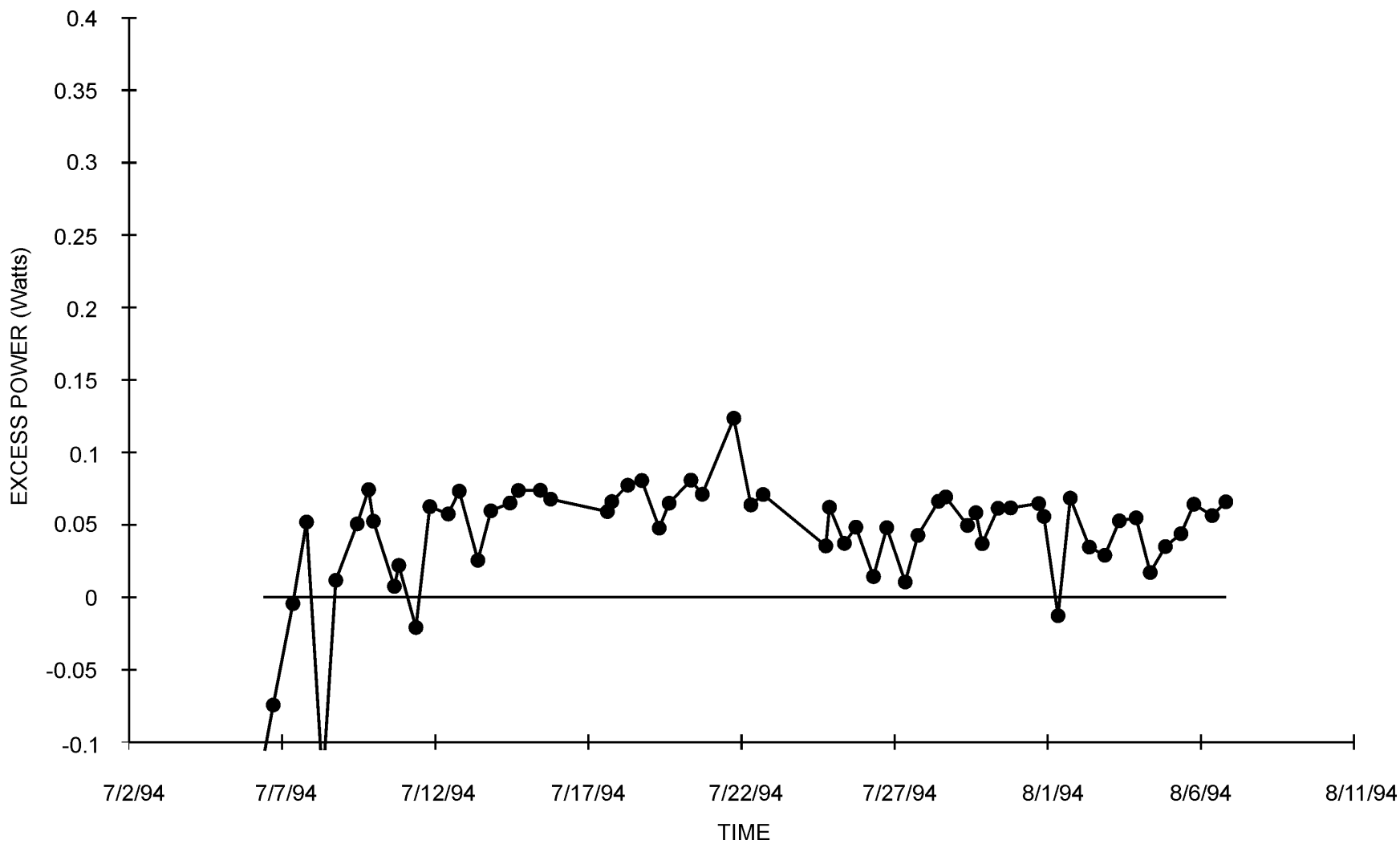

FIGURE 14. Excess Power Observed for an NRL Palladium Cathode in a Second Experiment, Cell D. This represents the only study showing excess power using NRL palladium cathodes.

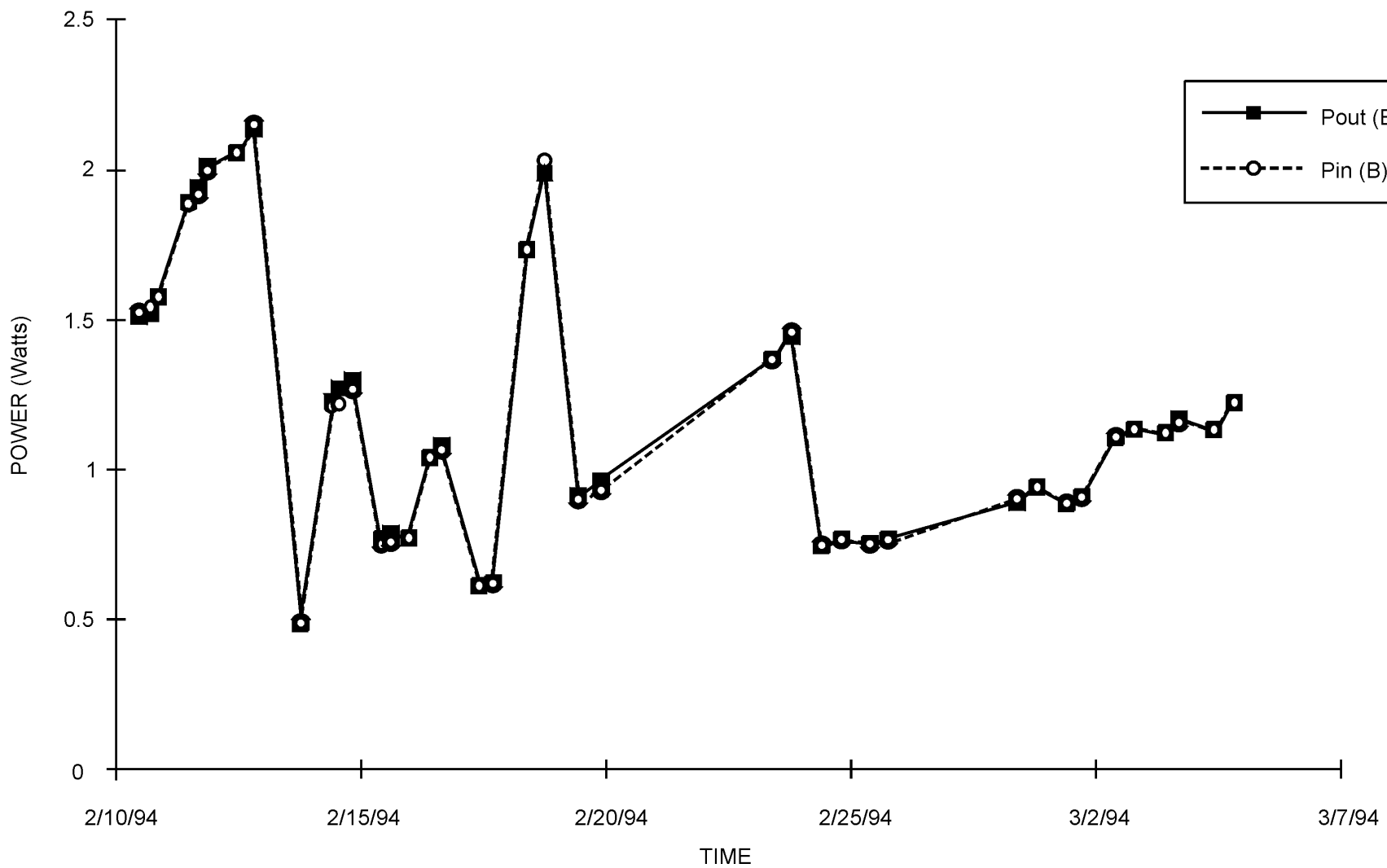

FIGURE 15. The Electrochemical Input Power and the Calorimetrically Measured Output Power for a Palladium Sheet Cathode Supplied by John Dash, Cell B. No excess power was observed.

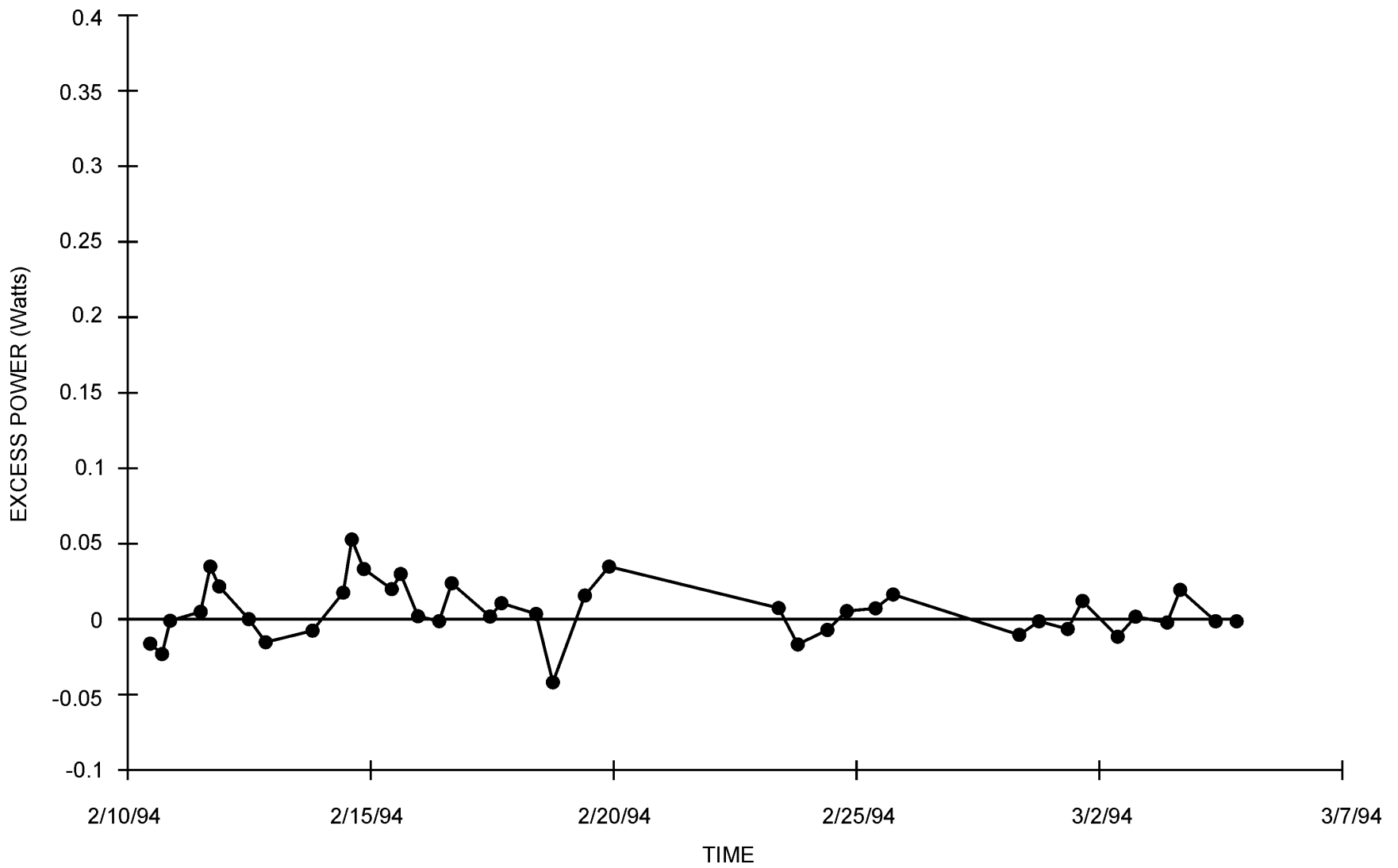

FIGURE 16. Excess Power Measurements for the John Dash Palladium Sheet Cathode, Cell B. All measurements are within  $\pm 40$  mW. No excess power was observed.

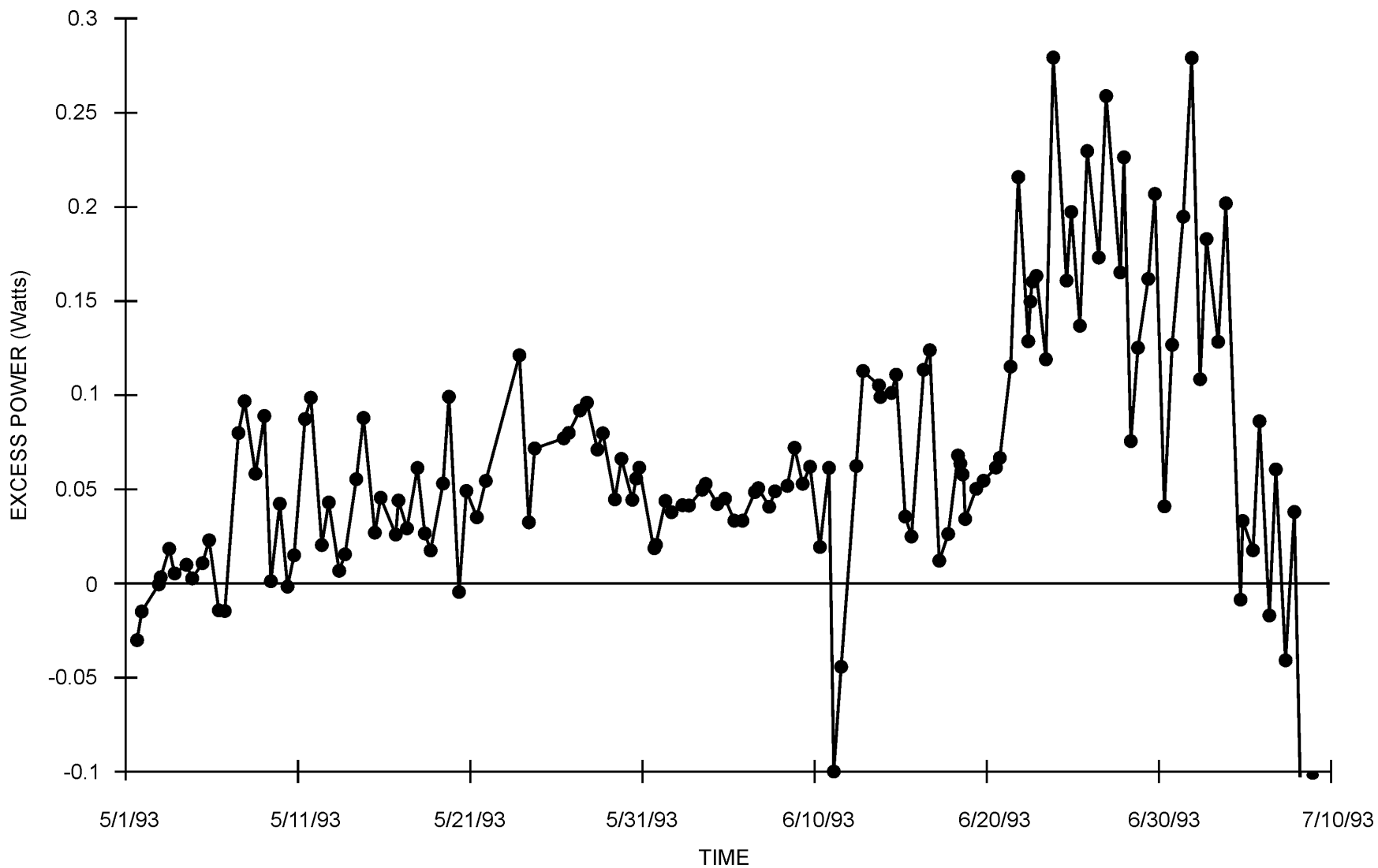

FIGURE 17. Excess Power Measurements for the 2-mm Palladium Rod Obtained From Martin Fleischmann, Cell D. Excess power peaks as large as 250 mW were observed later in this experiment.

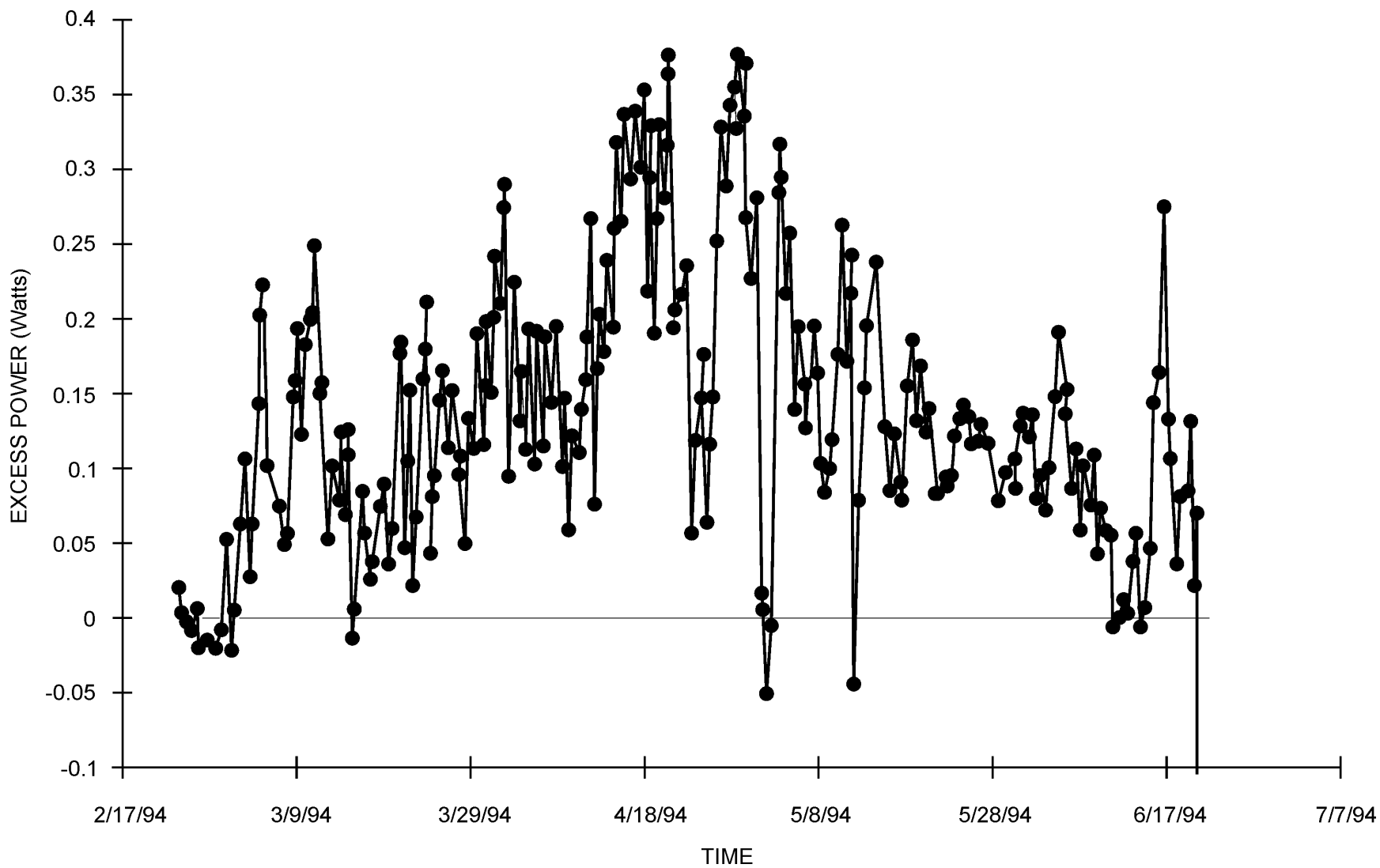

FIGURE 18. Excess Power Measurements for a Palladium-Cerium Alloy Rod (4.1 mm  $\times$  1.9 cm) Obtained from Martin Fleischmann, Cell C. Excess power peaks of 350 mW were observed.

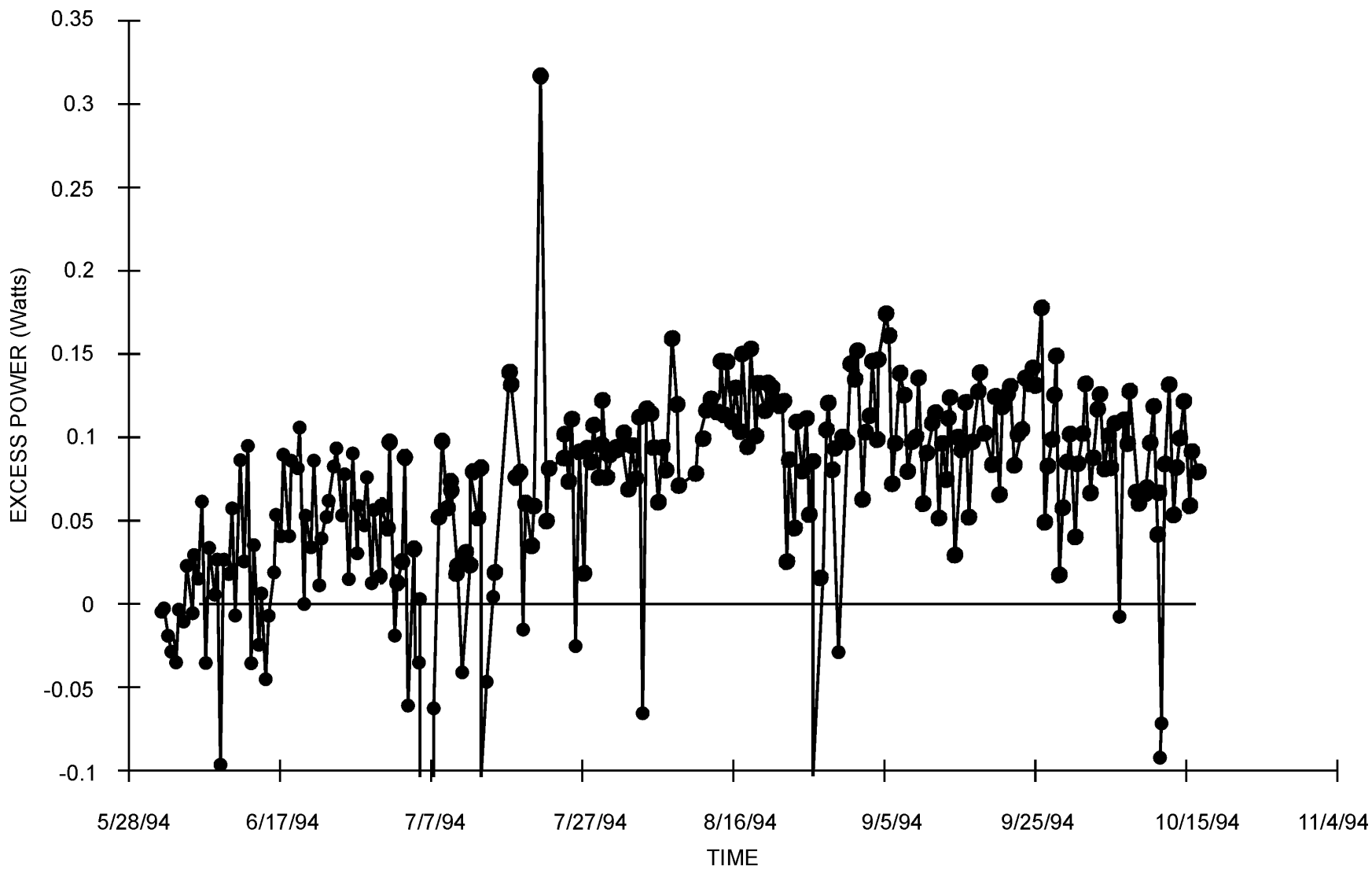

FIGURE 19. Excess Power Measurements for an NRL Palladium-Boron Rod (6.0 mm  $\times$  2.0 cm, 0.75 weight % boron), Cell B.

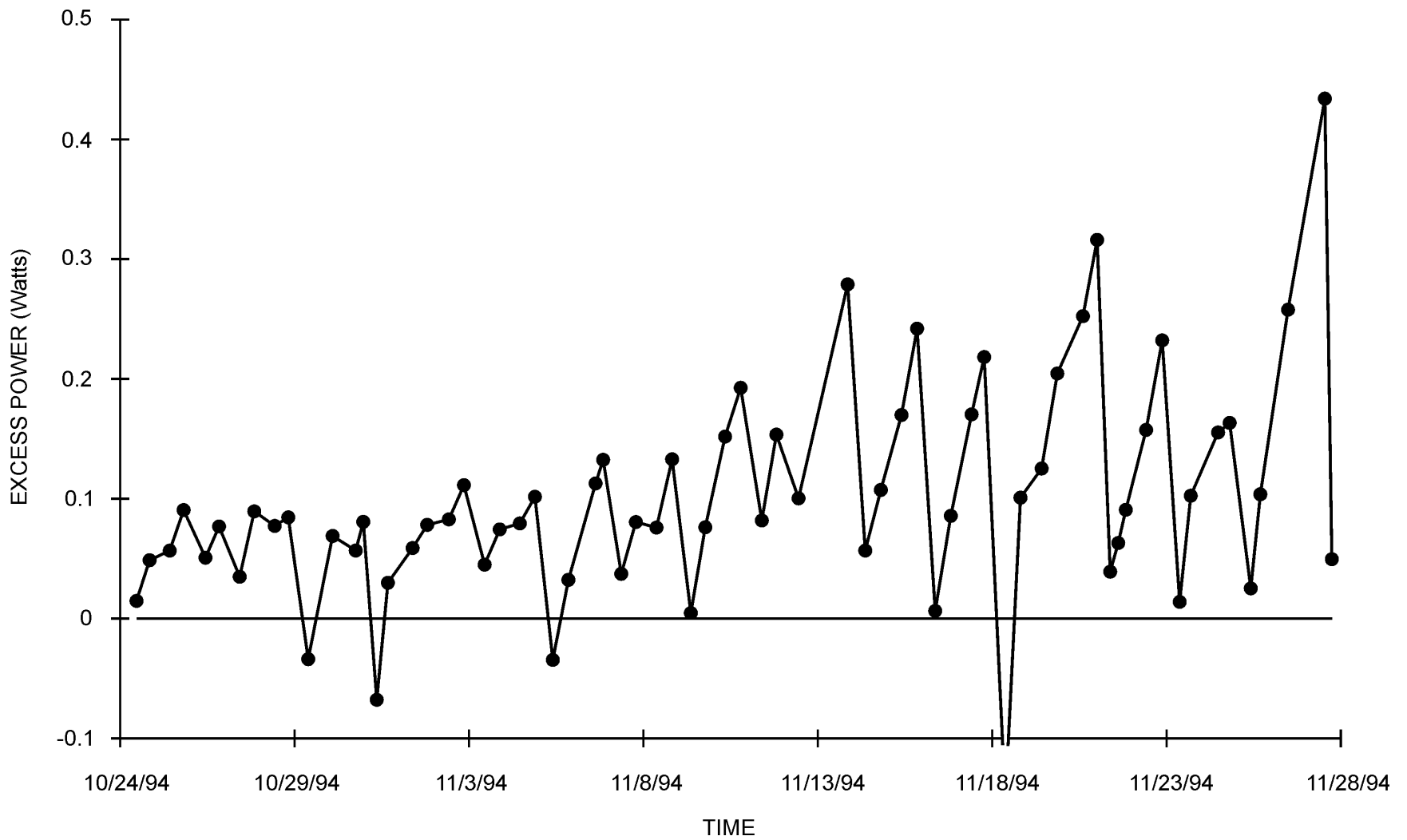

FIGURE 20. Excess Power Measurements for a Second Experiment Using the Same Palladium-Boron Rod as in Figure 19, Cell B.

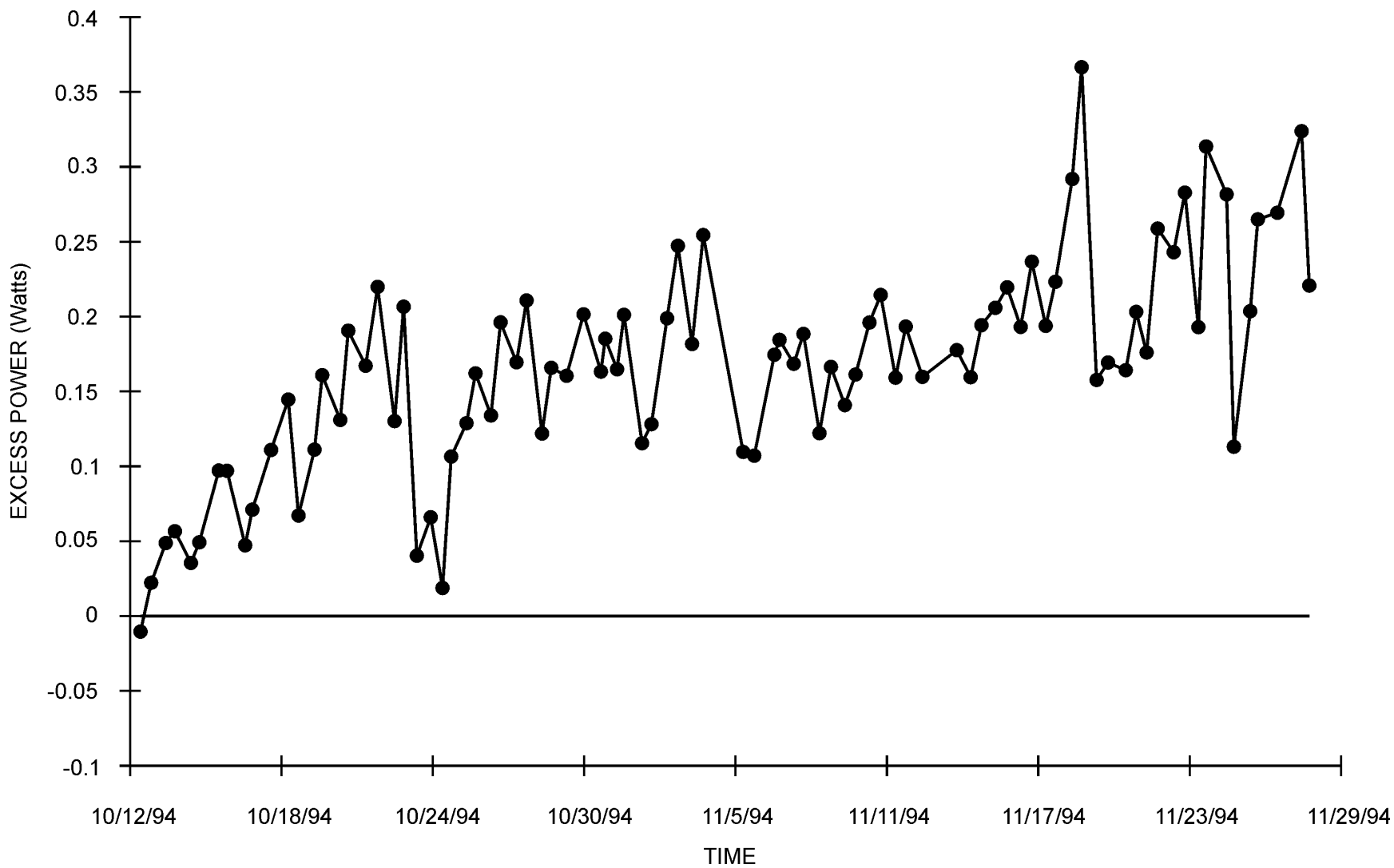

FIGURE 21. Excess Power Measurements for an NRL Palladium-Boron Rod (2.5 mm × 2.5 cm, 0.75 weight % boron), Cell C. A gradual increase in the excess power was observed. No flaws were visible for this cathode.

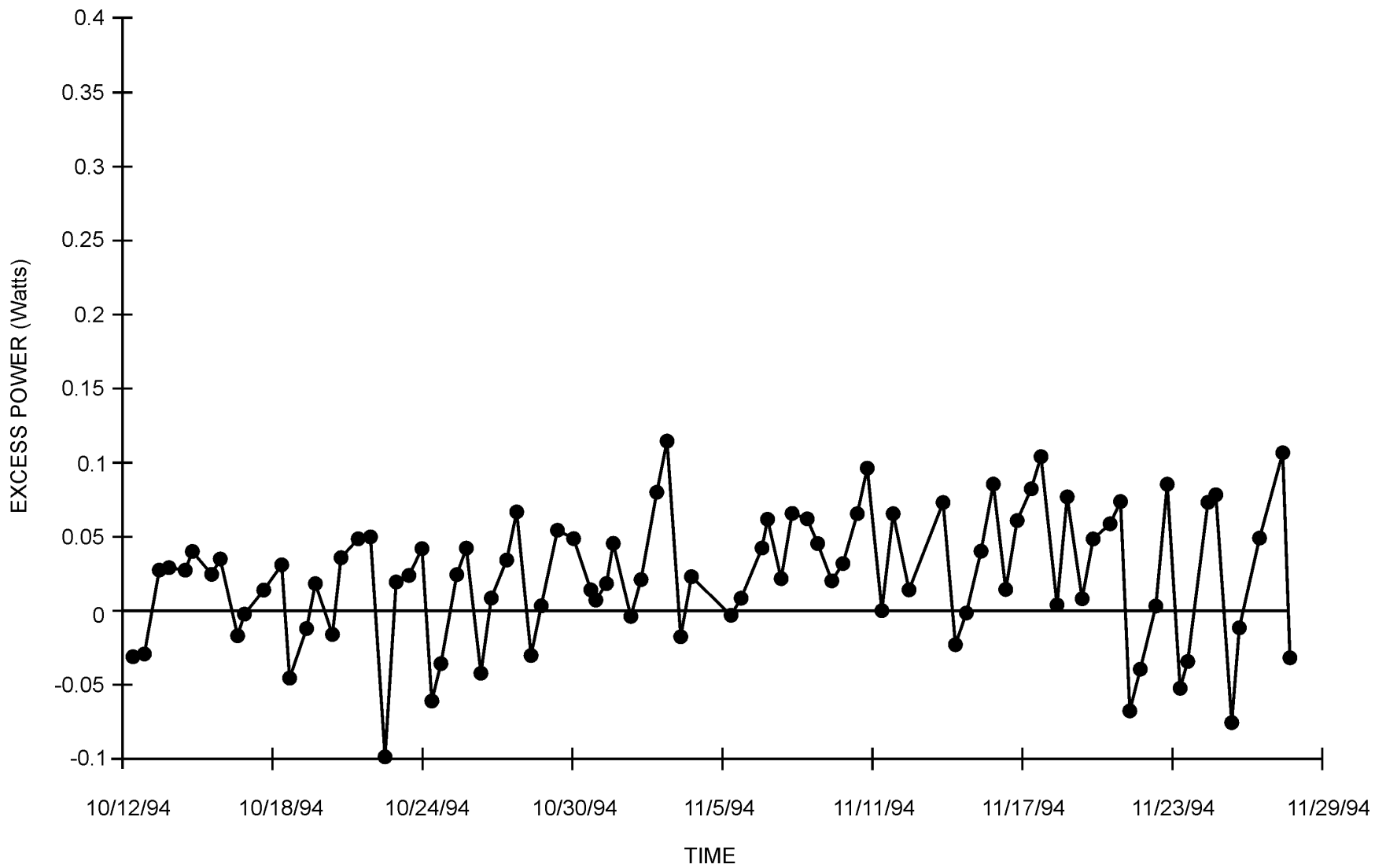

FIGURE 22. Experiment Showing No Significant Excess Power for an NRL Palladium-Boron Rod (2.5 mm × 2.5 cm, 0.75 weight % boron), Cell D. This rod contained a folded-over metal region that would act as a long crack.

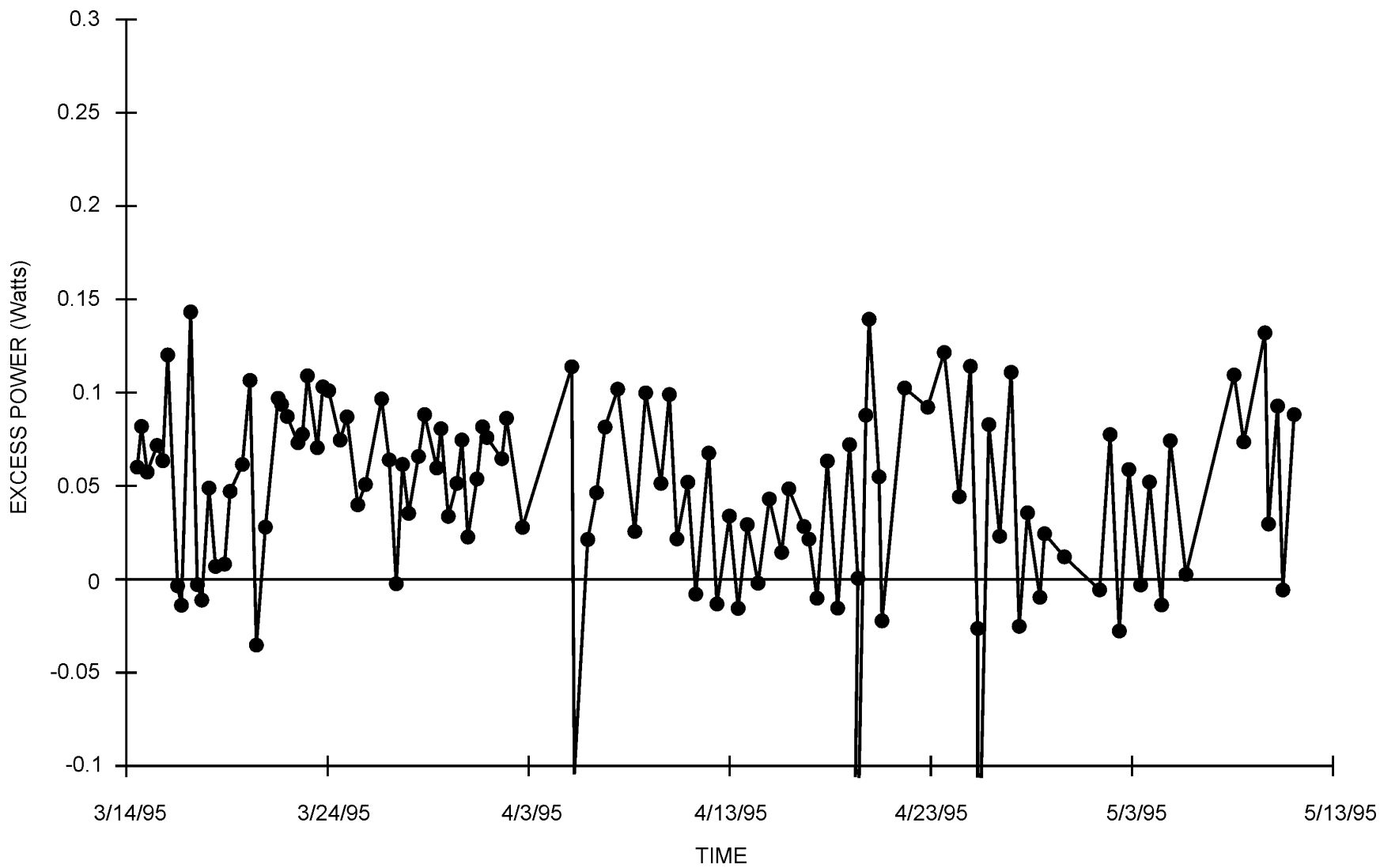

FIGURE 23. Excess Power Measurements for an NRL Palladium-Boron Rod (4.0 mm × 2.0 cm) Containing 0.50 Weight % Boron, Cell A. Excess power levels of 50-150 mW were observed.

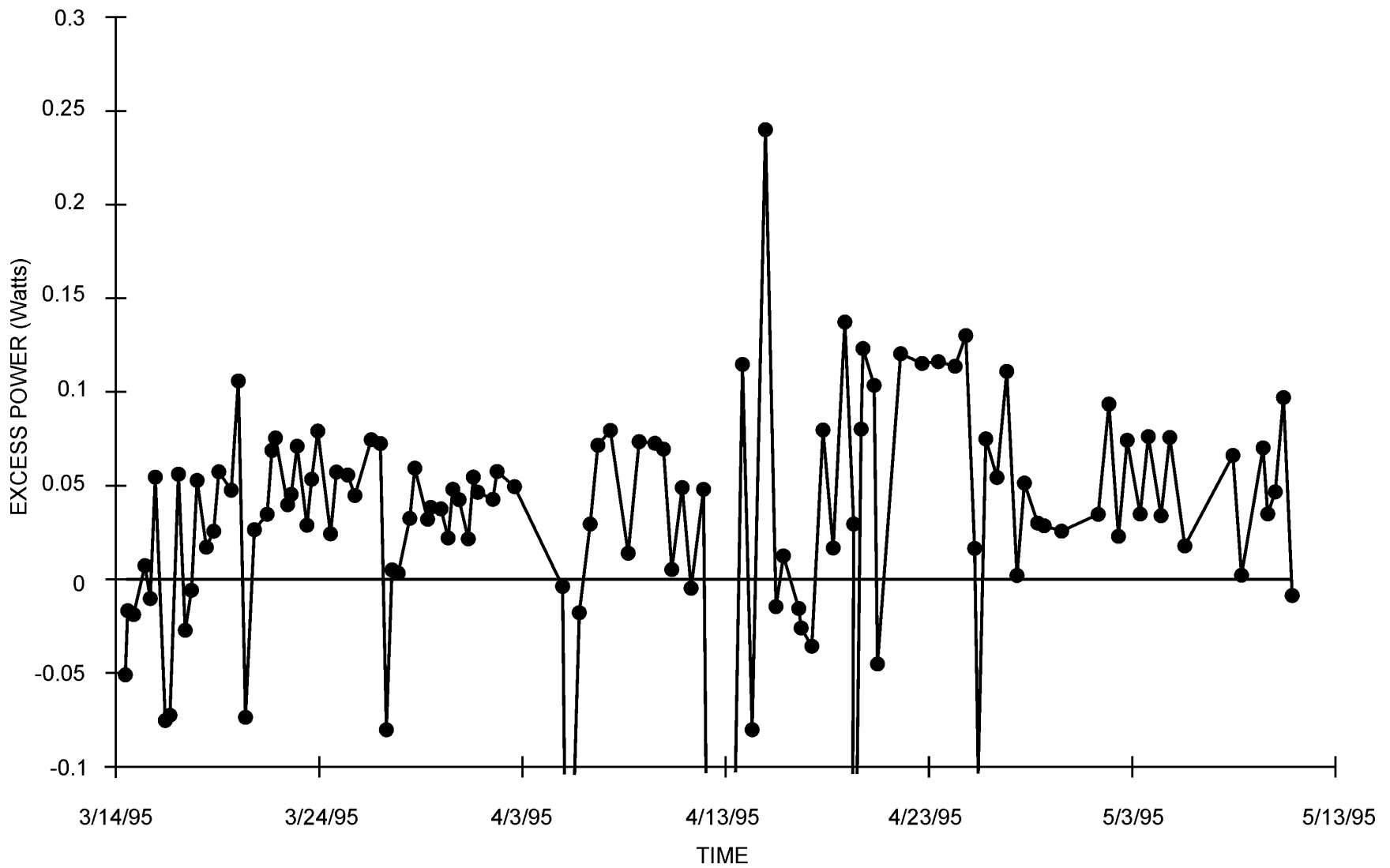

FIGURE 24. Excess Power Measurements for Another NRL Palladium-Boron Rod (4.0 mm × 2.0 cm) Containing 0.50 Weight % Boron, Cell B. Typical excess power levels are 50-150 mW.

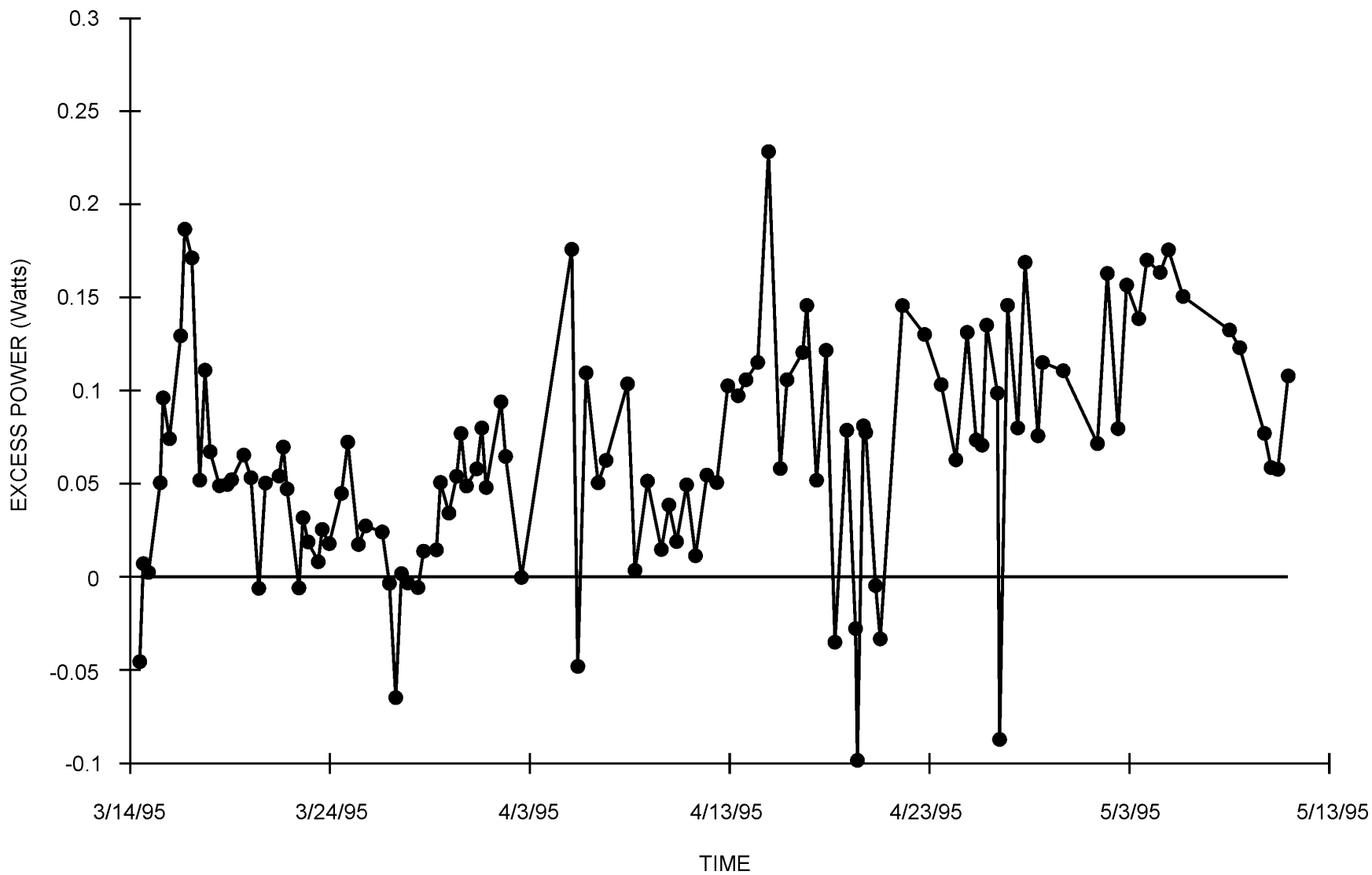

FIGURE 25. Excess Power Measurements for an NRL Palladium-Boron Rod (4.0 mm × 2.0 cm) Containing 0.25 Weight % Boron, Cell C. Typical excess power levels are 50-150 mW.

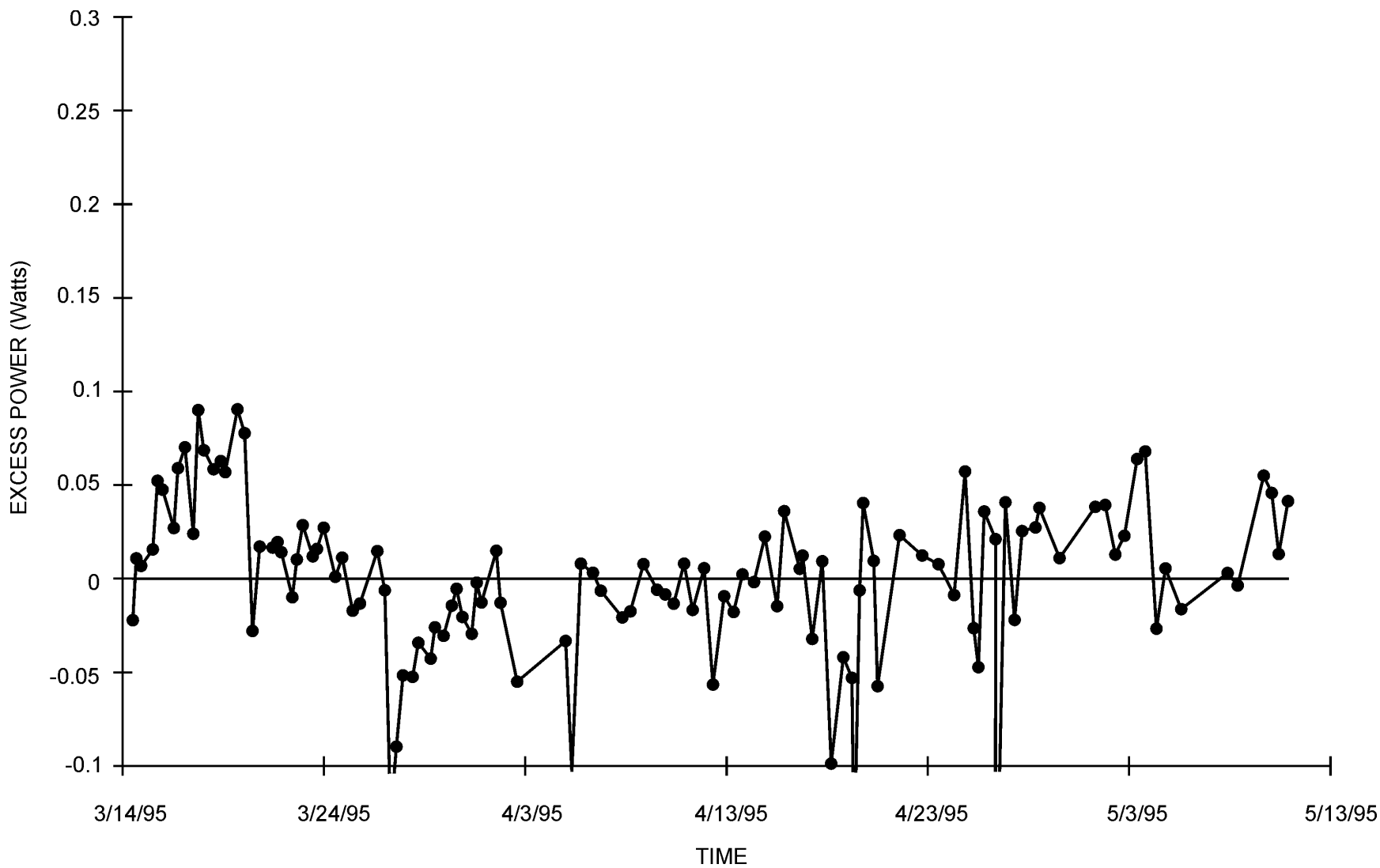

FIGURE 26. Excess Power Measurements for Another NRL Palladium-Boron Rod (4.0 mm × 2.0 cm) Containing 0.25 Weight % Boron, Cell D. A brief 5-day period of excess power was observed early in the experiment.

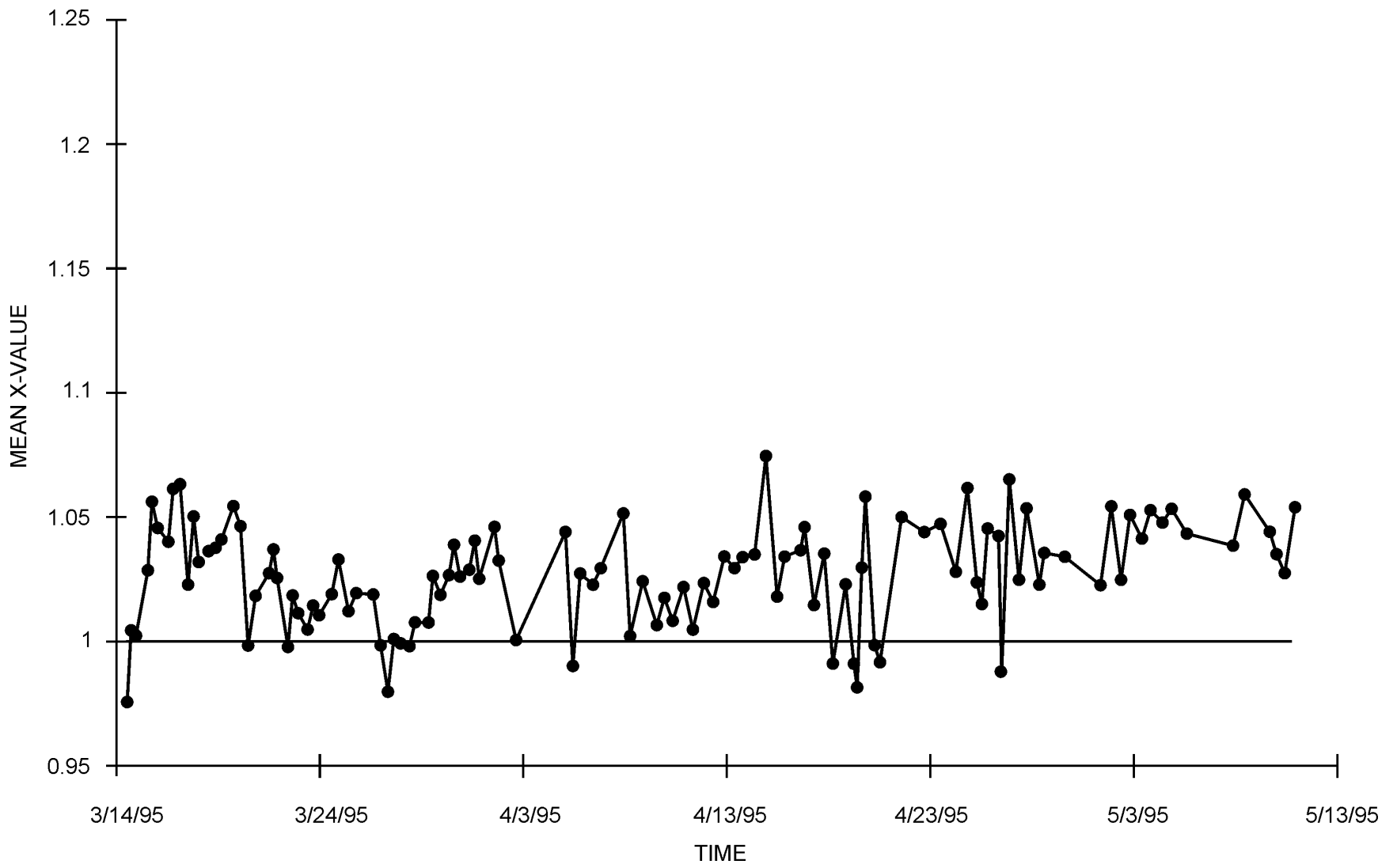

FIGURE 27. Ratio, X, of Output and Input Power for the Experiment Shown in Figure 25, Cell C.

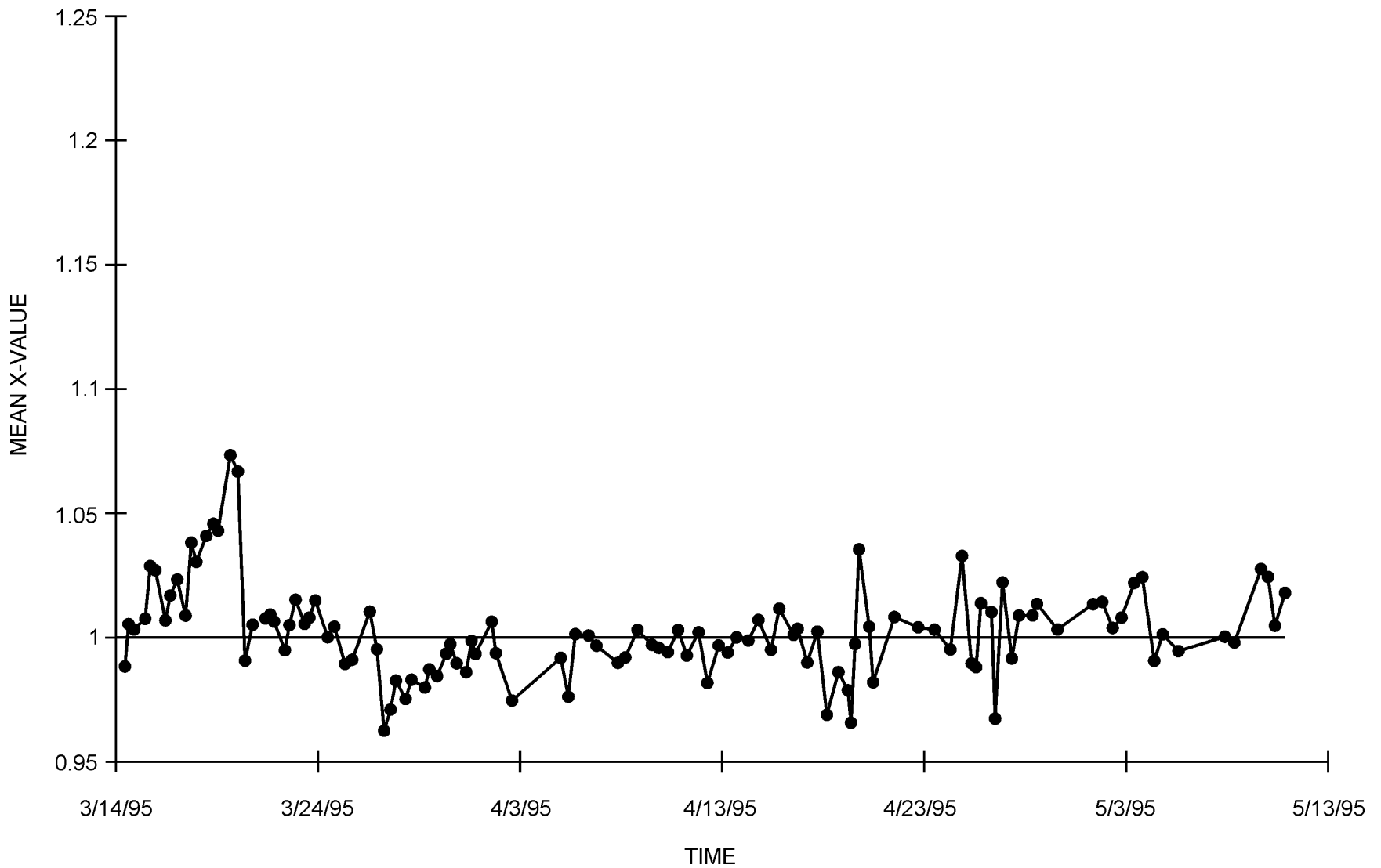

FIGURE 28. Ratio, X, of Output and Input Power for the Experiment Shown in Figure 26, Cell D. No excess power is measured except for early in the experiment.

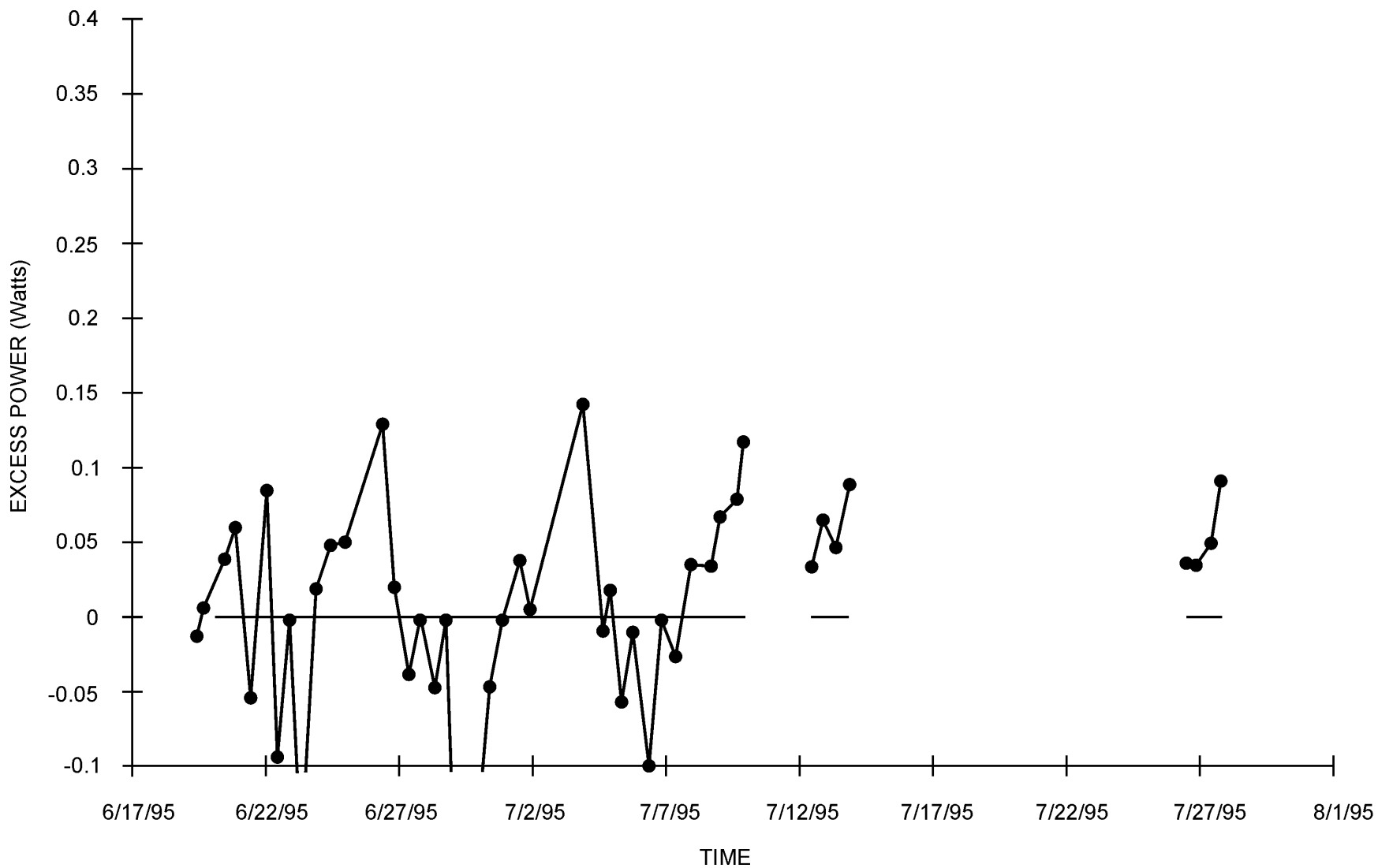

FIGURE 29. Excess Power Measurements for the Johnson-Matthey Palladium Wire (1 mm × 2.5 cm), Cell A. Calibrations following this experiment suggest no excess power.

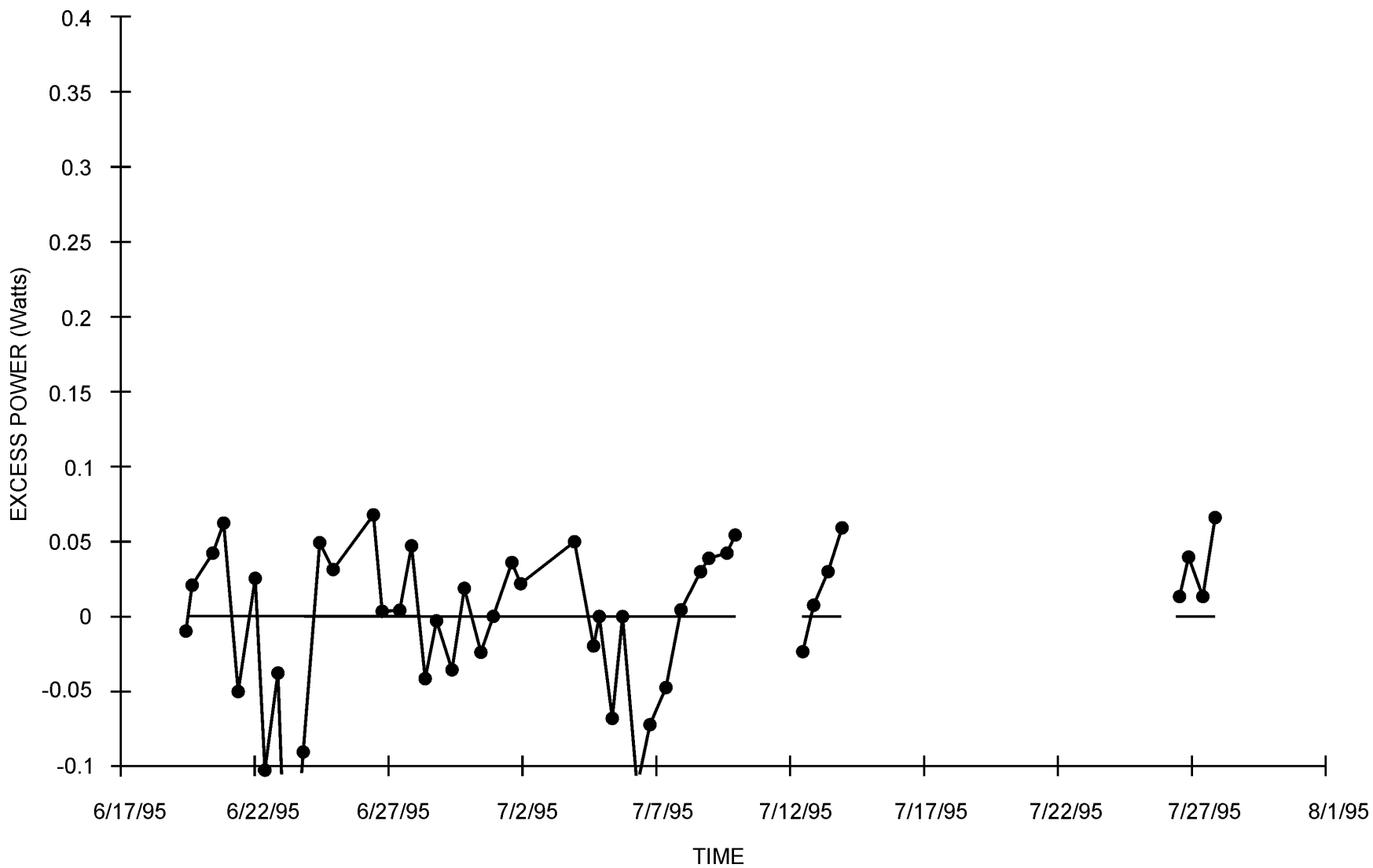

FIGURE 30. Excess Power Measurements for another Johnson-Matthey Palladium Wire (1 mm  $\times$  2.5 cm), Cell B. No significant excess power was observed.

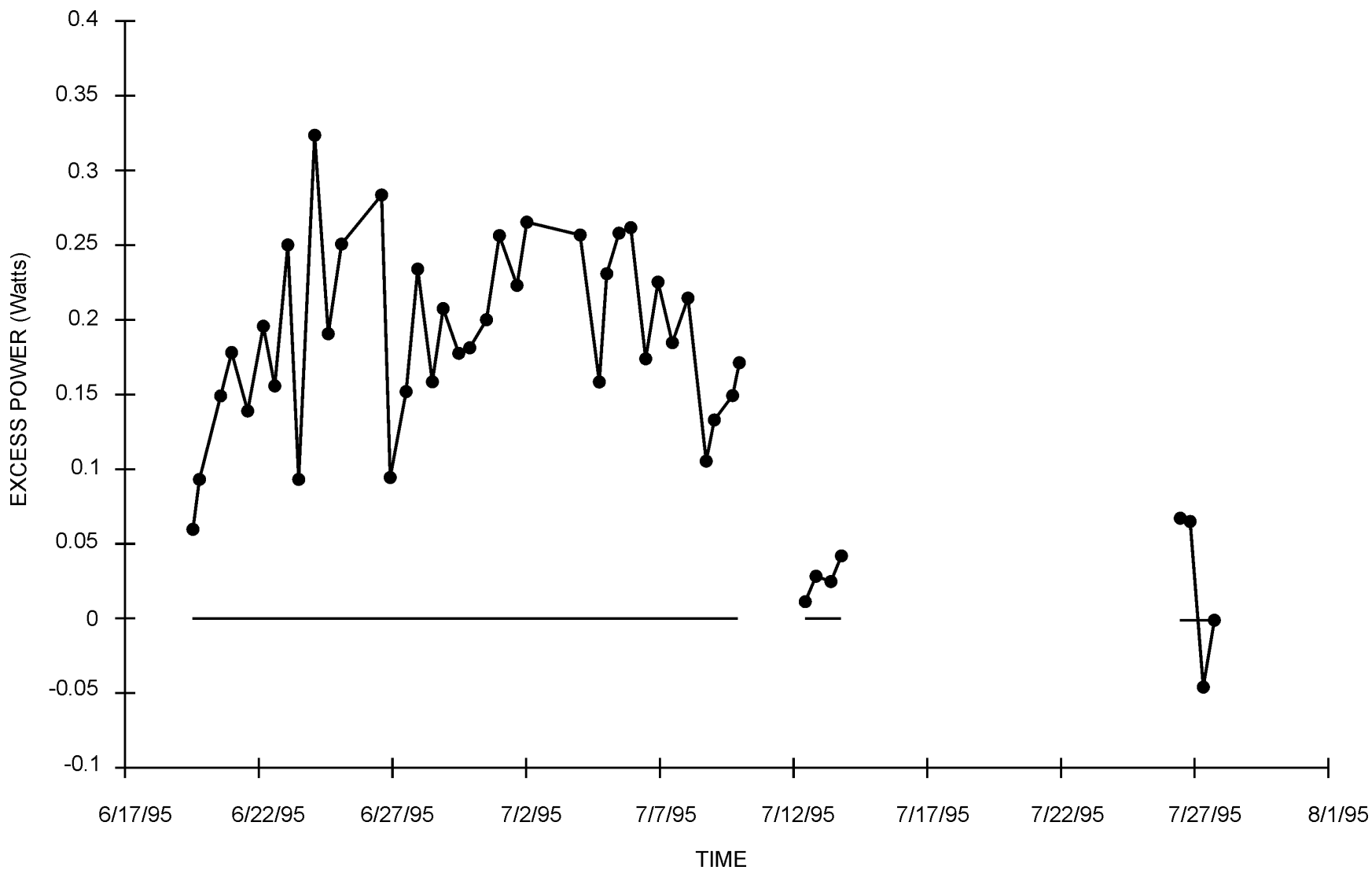

FIGURE 31. Excess Power Measurements for a Third Johnson-Matthey Palladium Wire (1 mm × 2.0 cm), Cell C. Significant excess power exceeding 200 mW was consistently observed. Calibrations checks following this experiment verify the excess power observations.

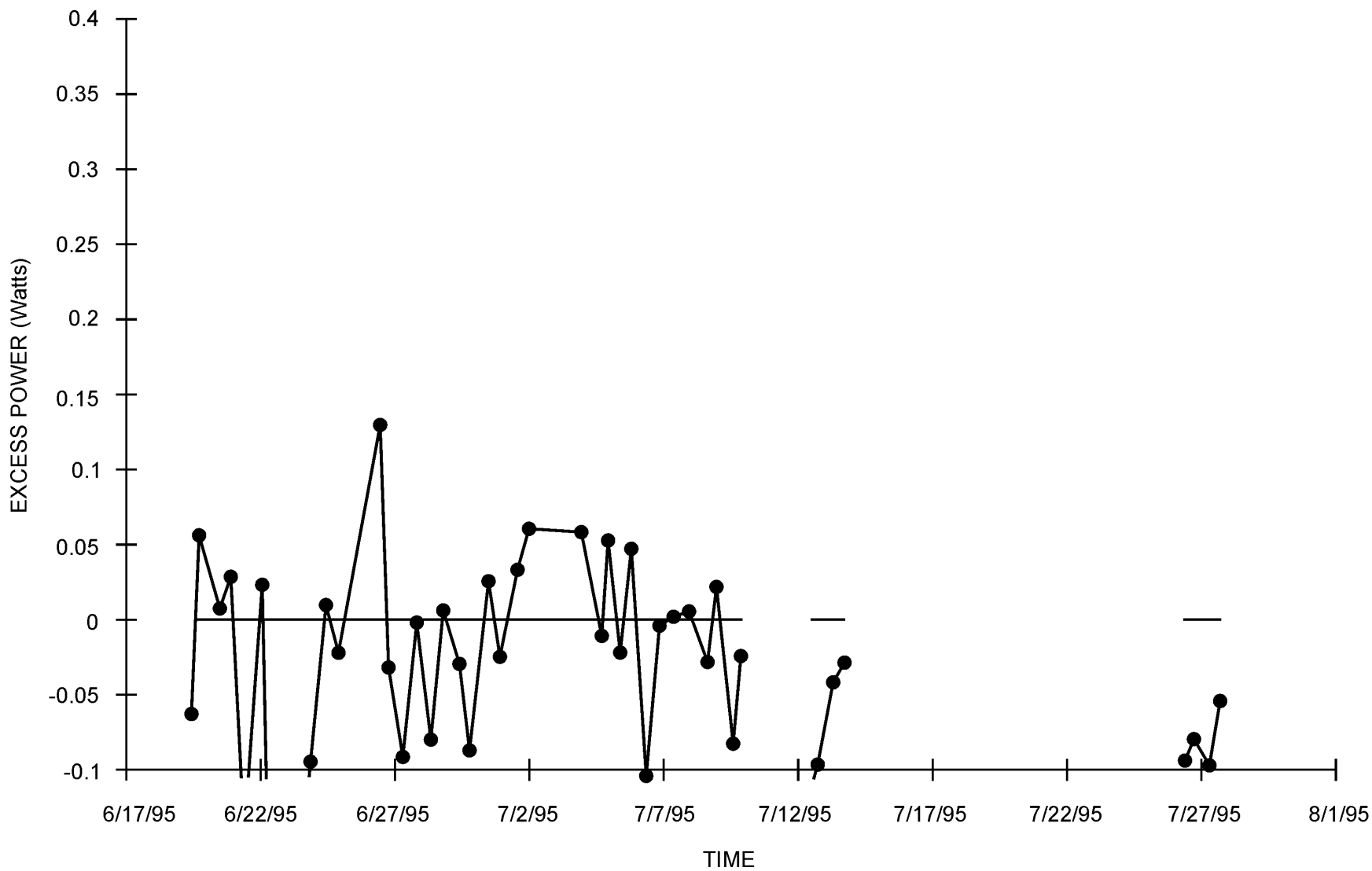

FIGURE 32. Excess Power Measurements for a Fourth Johnson-Matthey Palladium Wire (1 mm × 2.0 cm), Cell D. No significant excess power was observed. The calibration checks following this experiment, however, suggest a possibility of small excess power effects.

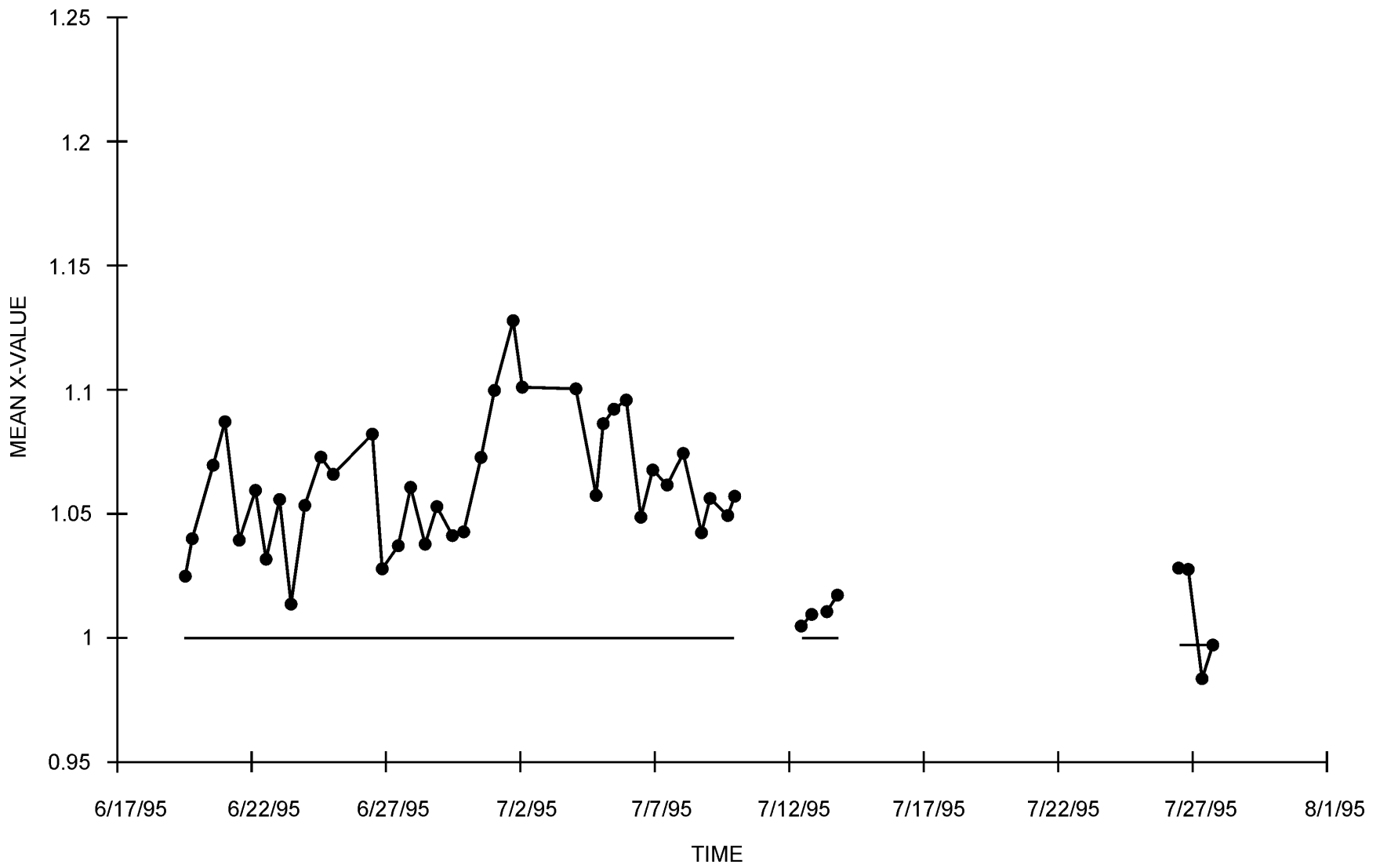

FIGURE 33. The Power Ratio, X, for the Experiment in Figure 31 That Produced Significant Excess Power, Cell C.

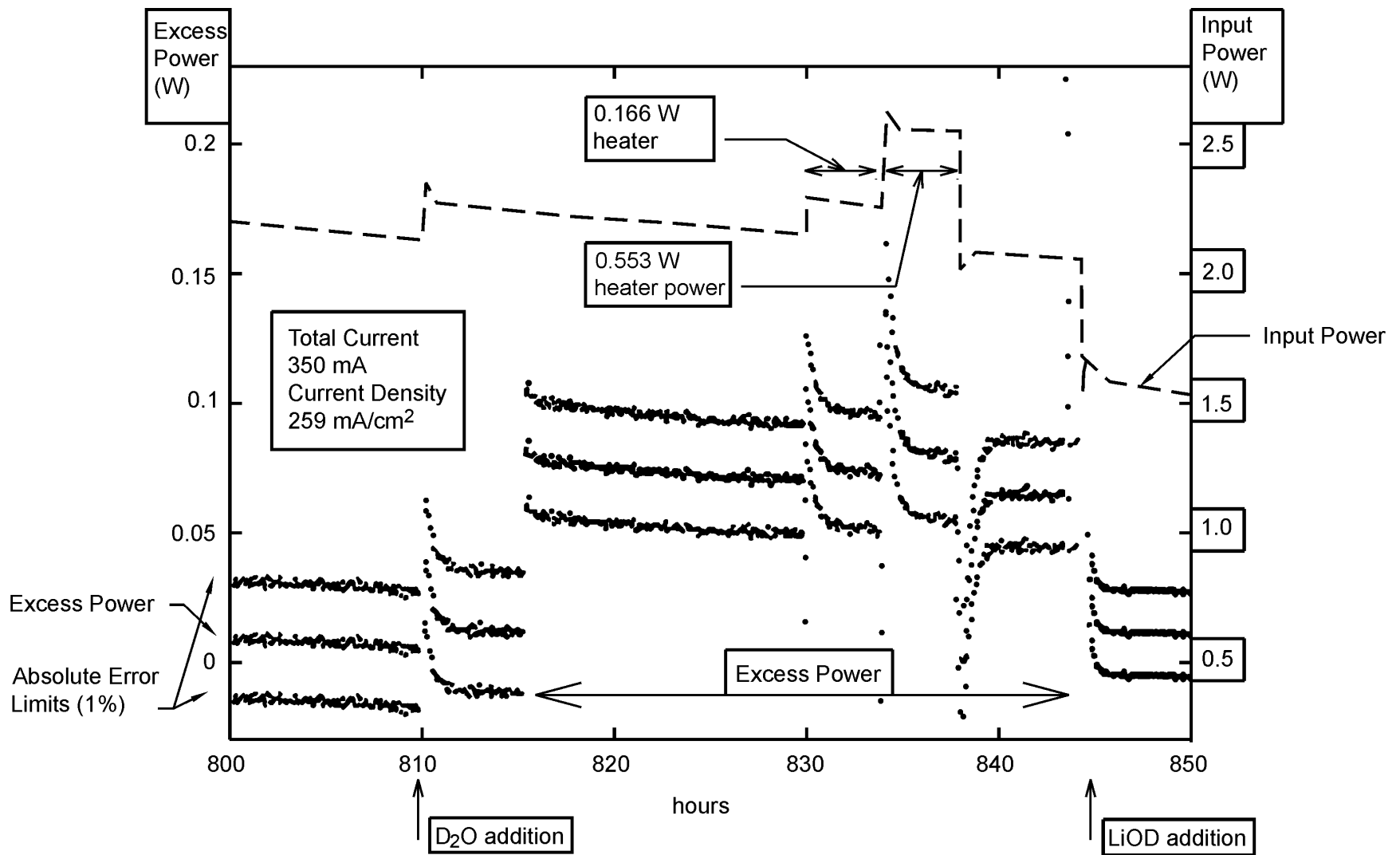

FIGURE 34. Excess Power Excursion for a 1-mm Johnson-Matthey Wire Cathode (1 mm × 4.3 cm) as Measured With the Improved China Lake Calorimeter. Excess power levels of approximately 75 mW are observed from 815 to 845 hours. Both the onset and the loss of the excess power effect were sudden.

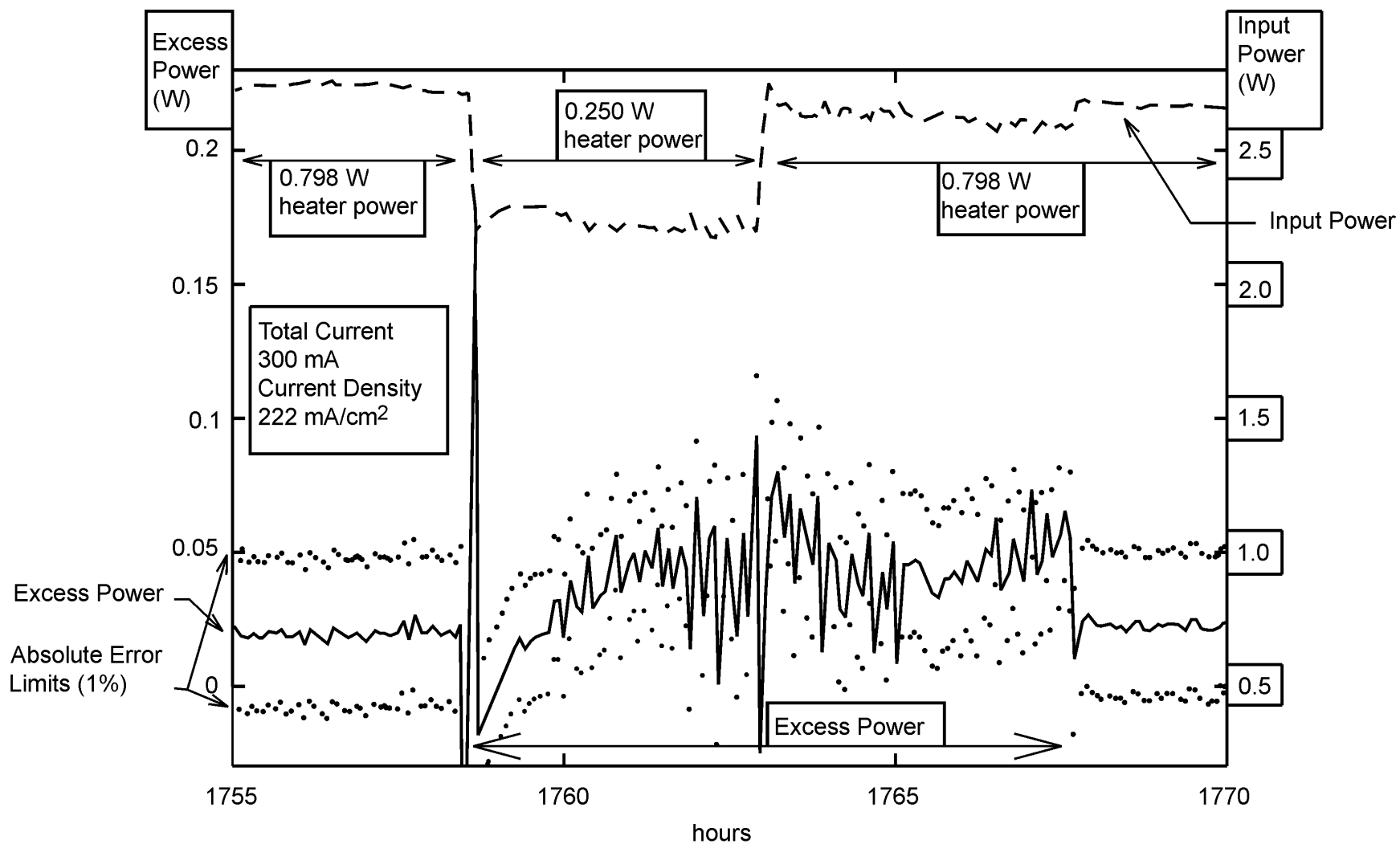

FIGURE 35. Fluctuating Excess Power Effects for the Same Johnson-Matthey Cathode as in Figure 34. The onset of excess power began shortly after the reduction in the heater power which changed the cell temperature.

## APPENDIXES

### Appendix A. TEMPERATURE-DEPENDENT CALORIMETRIC PARAMETERS

$$C_{P,D_2} = 28.9778 - 1.49226 \times 10^{-3} T + 4.14779 \times 10^{-6} T^2 + 0.26544 \times 10^{-5} T^3 \text{ (J mol}^{-1} \text{ K}^{-1}\text{)}$$

$$C_{P,O_2} = 23.1436 + 18.2628 \times 10^{-3} T - 6.605 \times 10^{-6} T^2 + 1.2118 \times 10^{-5} T^3 \text{ (J mol}^{-1} \text{ K}^{-1}\text{)}$$

$$C_{P,D_2O(g)} = 26.7006 + 21.2897 \times 10^{-3} T - 2.66774 \times 10^{-6} T^2 + 1.2907 \times 10^{-5} T^3 \text{ (J mol}^{-1} \text{ K}^{-1}\text{)}$$

$$C_{P,D_2O(liq)} = 200.13 - 495.9 \times 10^{-3} T + 573.07 \times 10^{-6} T^2 - 16.765 \times 10^{-5} T^3 \text{ (J mol}^{-1} \text{ K}^{-1}\text{)}$$

$$L_{D_2O(liq)} = 85263.9 - 173.429 T + 0.2586 T^2 - 1.91913 \times 10^{-4} T^3 - 1805569 T^{-1} \text{ (J mol}^{-1}\text{)}$$

$$\log P_{D_2O}^0 = 35.47686 - 3343.93 T^{-1} - 10.9 \log T + 0.0041645 T + 9.140567 (197.397 - T)$$

$$P = (0.98 P_{D_2O}^0) P^*$$

$$E_H = 1.5318346 - 0.0002067 (T - 273.15) \text{ (V)}$$

## Appendix B. ROOM TEMPERATURE CORRECTION

$$P = K_t(T_b - T_R) + K\Delta T \quad (\text{A-1})$$

Correction is needed that makes the measured power output at any bath and room temperature to be the same as when the measurements are made for  $T_b = 27.50^\circ\text{C}$  and  $T_R = 23.50^\circ\text{C}$

thus

$$P(T_b, T_R) = P(27.50^\circ\text{C}, 23.50^\circ\text{C}) \text{ From}$$

Equation A-1

$$K_t(T_b - T_R) + K\Delta T_{\text{obs}} = K_t(27.50 - 23.50) + K\Delta T$$

or

$$K_t(T_b - T_R) + K\Delta T_{\text{obs}} = K_t(4.00) + K\Delta T$$

solving for  $\Delta T$

$$\Delta T = \Delta T_{\text{obs}} + K_t K^{-1} (T_b - T_R - 4)$$

## Appendix C. PROBABILITIES OF EXPERIMENTAL HEAT AND HELIUM CORRELATIONS

For our 33 experiments involving heat and helium measurements, excess heat was measured in 21 cases and excess helium was observed in 18 studies. Thus 12 experiments yielded no excess heat and 15 measurements gave no excess helium. If one uses these experimental results as random probabilities of  $P_h = 21/33$  for excess heat and  $P_{He} = 18/33$  for excess helium, then the probability of random agreement ( $P_a$ ) for our heat and helium measurements would be

$$P_a = P_h * P_{He} + (1-P_h)(1-P_{He}) = 0.512$$

and the probability of random disagreement ( $P_d$ ) would be  $P_d = 1 - P_a = 0.488$ . The presence or absence of excess heat was always recorded prior to the helium measurement and was not communicated to the helium laboratory. Based on our experimental results, the random probability of the helium measurement correlating with the calorimetric measurement is not exactly one-half. This is analogous to flipping a weighted coin where heads are more probable than tails. The probability of exactly three mismatches in 33 experiments, therefore, would be

$$P_3 = \frac{33!}{30!3!} (0.512)^{30} (0.488)^3 = 1.203 \times 10^{-6}$$

Similar terms can be calculated for two ( $P_2 = 1.221 \times 10^{-7}$ ), one ( $P_1 = 8.009 \times 10^{-9}$ ), or zero ( $P_0 = 2.546 \times 10^{-10}$ ) mismatches in 33 experiments. The total probability of three or less mismatches in 33 studies would be

$$P = P_3 + P_2 + P_1 + P_0 = 1.333 \times 10^{-6} = \frac{1}{750,000}$$

This statistical treatment shows that the odds are approximately one in 750,000 that our complete set of heat and helium results could be this well correlated due to random experimental errors in our calorimetry and helium measurements. Furthermore, it is very unlikely that random errors would consistently yield helium-4 production rates in the appropriate range of  $10^{11} - 10^{12}$  atoms/s per watt of excess power.

## Appendix D

### EVIDENCE SUPPORTING ANOMALOUS EFFECTS

#### CALORIMETRIC EVIDENCE

1. The correlation of excess power with cathode materials (Table 10).
2. Magnitude of excess power agrees with SRI and other laboratories.
3. Excess power density agrees with SRI and other laboratories (1-5 W/cm<sup>3</sup> Pd for current densities of 100-200 mA/cm<sup>2</sup>).
4. Reproducibility problem is similar to other laboratories for excess heat production.
5. The precise detection and correction for apparent excess power due to recombination effects in co-deposition experiments (see Figure 6).
6. The high-success ratio for excess power using Pd-B materials prepared by NRL.
7. The low-success ratio for excess power using NRL Pd-Ag and NRL Pd samples that showed poor loading.
8. The low-success ratio for excess power in co-deposition experiments where the volume of dense palladium was very small.
9. Correlation between excess power and loading measurements for NRL Pd-B samples (see Figures 21 and 22 and Table 8).
10. High-success rate (4/4) for excess power using materials supplied by Martin Fleischmann. This demonstrates reproducibility between laboratories when good cathode materials are identified.
11. The low-success rate for palladium-plated cathodes where the palladium volume is small.
12. Agreement with other laboratories on electrolysis time periods and current densities required for excess power production.
13. No excess power in twelve H<sub>2</sub>O + LiOH control experiments.
14. High-success rate for excess power in repeated experiments using the same cathode.

## HEAT AND HELIUM EVIDENCE

1. The correlation of excess heat and helium production or no excess heat and no excess helium in 30 experiments.
2. Magnitude of excess helium yields helium production rates of  $10^{11}$  -  $10^{12}$  atoms per second per watt of excess power that is consistent with typical deuteron fusion reactions.
3. Agreement between three different laboratories that performed helium measurements on our samples.
4. Agreement between samples collected in both glass and metal flasks.
5. Resolution of the helium detection limit question that is consistent with background helium levels determined later and with the known rate of helium diffusion through glass.
6. No excess power and no excess helium in seven  $\text{H}_2\text{O} + \text{LiOH}$  control studies.
7. Excellent agreement for background helium levels when no excess power was measured and metal flasks were used to collect samples ( $4.5 \pm 0.5$  ppb  $^4\text{He}$ ).
8. Reports from other laboratories for helium-4 production in deuterated palladium systems.

## ANOMALOUS RADIATION EVIDENCE

1. Exposure of X-ray films in two experiments producing excess power. No exposure of similar films in many experiments where no excess power was present.
2. Anomalous high counts for several different GM detectors when experiments were running.
3. No anomalous count rates when experiments were turned off.
4. Anomalous high counts for NaI detectors.
5. Correlations of anomalous radiation with expected time periods required to load the palladium with deuterium.
6. More rapid appearance of anomalous radiation in co-deposition experiments.
7. Decrease in anomalous radiation when the detectors were moved away from the electrolysis cells. This was observed on many occasions.

## TRITIUM PRODUCTION EVIDENCE

1. Somewhat higher levels of tritium than expected from theoretical calculations in a few experiments.